



**EUROPEAN NEW CAR ASSESSMENT PROGRAMME
(Euro NCAP)**



TEST PROTOCOL – AEB/LSS VRU systems

Version 4.0.0
June 2021

Copyright 2021 ©Euro NCAP - This work is the intellectual property of Euro NCAP. Permission is granted for this material to be shared for non-commercial, educational purposes, provided that this copyright statement appears on the reproduced materials and notice is given that the copying is by permission of Euro NCAP. To disseminate otherwise or to republish requires written permission from Euro NCAP.

EUROPEAN NEW CAR ASSESSMENT PROGRAMME (Euro NCAP)

TEST PROTOCOL – AEB VRU SYSTEMS

Table of Contents

1	INTRODUCTION	1
2	DEFINITIONS	2
3	REFERENCE SYSTEM	5
3.1	Convention	5
3.2	Lateral Path Error	6
3.3	Profiles for impact speed determination	7
4	MEASURING EQUIPMENT	9
4.2	Measurements and Variables	9
4.3	Measuring Equipment	10
4.4	Data Filtering	10
5	EURO NCAP VRU TARGETS	11
5.1	Specification	11
6	TEST CONDITIONS	12
6.1	Test Track	12
6.2	Weather Conditions	13
6.3	Surroundings	13
6.4	VUT Preparation	14
7	TEST PROCEDURE	16
7.1	VUT Pre-test Conditioning	16
7.2	Test Scenarios	17
7.3	Test Conduct	37
7.4	Test Execution	38
ANNEX A	OBSTRUCTION DIMENSIONS	41
ANNEX B	TESTING AT LOW AMBIENT LIGHTING CONDITIONS	42
ANNEX C	BRAKE APPLICATION PROCEDURE	60

1 INTRODUCTION

Accidents between cars and vulnerable road users are one of the most frequent accidents happening on the roads due to driver distraction or misjudgement.

Typical accidents between cars and vulnerable road users occur at city speeds where pedestrians and cyclists cross the path of the vehicle. These types of accidents usually coincide with severe injuries and leave the driver with very little reaction time to apply the brakes.

To support the driver in avoiding when possible or mitigating such crashes, car manufactures offer avoidance technology that reacts to the situation by autonomous braking and at higher speeds may issue warnings to alert the driver. Systems that specifically look for and react to vulnerable road users like pedestrians, cyclists and motorcyclists are called AEB/LSS VRU systems.

This protocol specifies the AEB/LSS VRU test procedure for Car-to-Pedestrian, Car-to-Bicyclist and Car-to-Motorcyclist scenarios, which are part of Vulnerable Road User protection.

Note:

Active Safety scoring in VRU is conditional to the total points achieved in subsystem tests, i.e. the sum of pedestrian Headform, Upper Legform & Lower Legform scores.

If the subsystem total test score is lower than 18 points, no points are available for AEB/LSS VRU, regardless whether the system is fitted and would achieve a good score.

DEFINITIONS

Throughout this protocol the following terms are used:

Peak Braking Coefficient (PBC) – the measure of tyre to road surface friction based on the maximum deceleration of a rolling tyre, measured using the American Society for Testing and Materials (ASTM) E1136-10 (2010) standard reference test tyre, in accordance with ASTM Method E 1337-90 (reapproved 1996), at a speed of 64.4km/h, without water delivery. Alternatively, the method as specified in UNECE R13-H.

Autonomous Emergency Braking (AEB) – braking that is applied automatically by the vehicle in response to the detection of a likely collision to reduce the vehicle speed and potentially avoid the collision.

Forward Collision Warning (FCW) – an audiovisual warning that is provided automatically by the vehicle in response to the detection of a likely collision to alert the driver.

Autonomous Emergency Steering (AES) – steering that is applied automatically by the vehicle in response to the detection of a likely collision to steer the vehicle and potentially avoid the collision.

Emergency Steering Support (ESS) – a system that supports the driver steering input in response to the detection of a likely collision to alter the vehicle path and potentially avoid a collision.

Vehicle width – the widest point of the vehicle ignoring the rear-view mirrors, side marker lamps, tyre pressure indicators, direction indicator lamps, position lamps, flexible mud-guards and the deflected part of the tyre side-walls immediately above the point of contact with the ground.

Car-to-Pedestrian – a collision between a vehicle and an adult or child pedestrian in its path, when no braking and/or steering action is applied.

Car-to-Bicyclist – a collision between a vehicle and an adult bicyclist in its path, when no braking and/or steering is applied.

Car-to-Bicyclist Dooring Adult (CBDA) – a collision between the vehicle's door and a bicyclist traveling alongside the parked vehicle.

Car-to-Motorcyclist – a collision between a vehicle and a Motorcyclist in its path, when no braking and/or steering is applied.

Vehicle under test (VUT) – means the vehicle tested according to this protocol with a pre-crash collision mitigation or avoidance system on board.

Euro NCAP Pedestrian Target (EPTa) – means the adult pedestrian target used in this protocol as specified in ISO 19206-2:2018

Euro NCAP Child Target (EPTc) – means the child pedestrian target used in this protocol as specified in ISO 19206-2:2018

Euro NCAP Bicyclist Target (EBT) – means the bicyclist and bike target used in this protocol as specified in ISO 19206-4:2020

Euro NCAP Motorcyclist Target (EMT) – means the Motorcyclist target used in this protocol as specified in the [deliverable D2.1 of the MUSE project](#) (Fritz and Wimmer 2019) which at time of publication is to be replaced with ISO 19206-5.

Time To Collision (TTC) – means the remaining time before the VUT strikes the EPT, assuming that the VUT and EPT would continue to travel with the speed it is travelling.

T_{AEB} – means the time where the AEB system activates. Activation time is determined by identifying the last data point where the filtered acceleration signal is below -1 m/s^2 , and then going back to the point in time where the acceleration first crossed -0.3 m/s^2

T_{FCW} – means the time where the audible warning of the FCW starts. The starting point is determined by audible recognition.

Vimpact – means the speed at which the profiled line around the front end of the VUT coincides with the virtual box around the EPTa, EPTc, EBT and EMT as shown in the right part of the figures below.

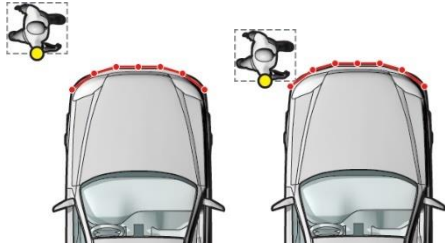

Figure 2-1:Front end profile and EPT

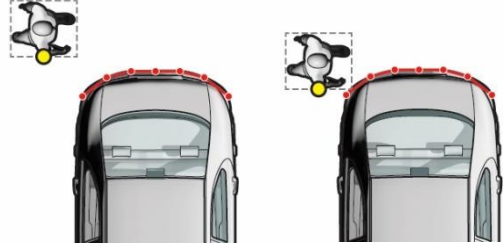

Figure 2-2:Rear end profile and EPT

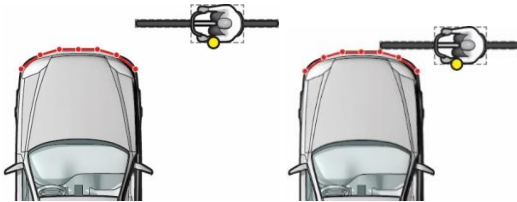

Figure 2-3:Front end profile and EBT

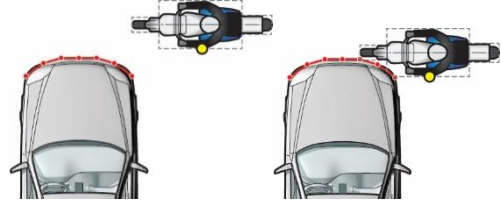

Figure 2-4:Front end profile and EMT

3 REFERENCE SYSTEM

3.1 Convention

3.1.1 For VUT, EPT, EBT and EMT use the convention specified in ISO 8855:1991 in which the x-axis points towards the front of the vehicle, the y-axis towards the left and the z-axis upwards (right hand system), with the origin at the most forward point on the centreline of the VUT for dynamic data measurements as shown in Figure 3-1.

3.1.2 Viewed from the origin, roll, pitch and yaw rotate clockwise around the x, y and z axes respectively. Longitudinal refers to the component of the measurement along the x-axis, lateral the component along the y-axis and vertical the component along the z-axis.

3.1.3 This reference system should be used for both left (LHD) and right hand drive (RHD) vehicles tested.

3.1.4 The nearside is swapped as per LHD and RHD vehicles. Figure 3-1 shows the near and farside of the vehicle for a left hand driven (LHD) vehicle.

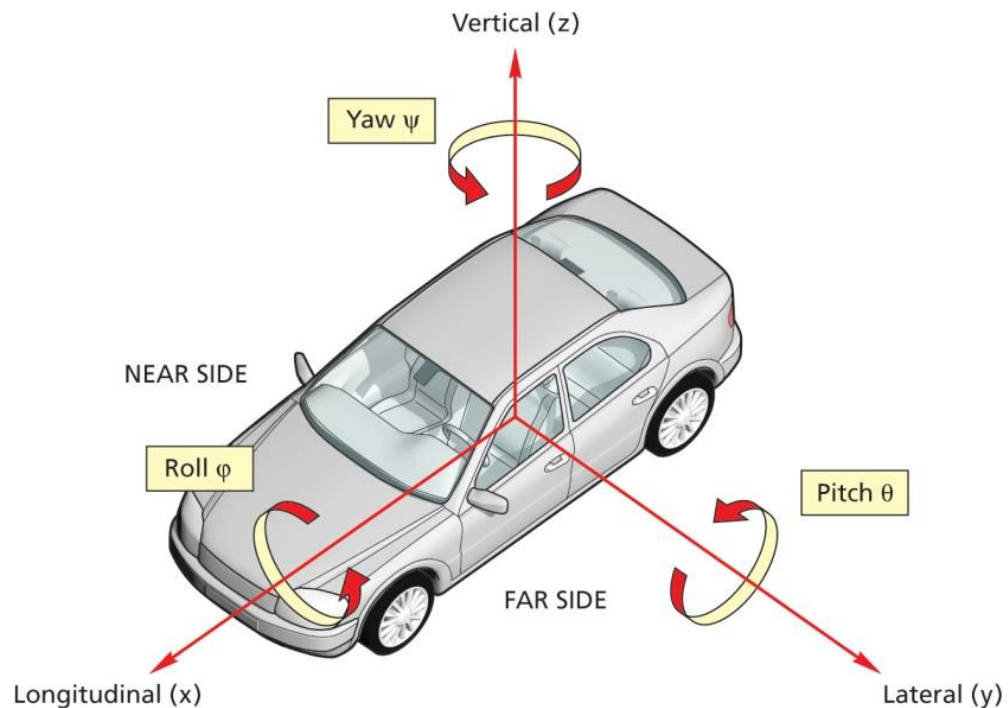

Figure 3-1: Coordinate system and notation (LHD & RHD) and nearside – farside for LHD vehicle

3.2 Lateral VUT Path Error

3.2.1 The lateral offset ($Y_{VUT-error}$) is determined as the lateral distance between the centre of the front of the VUT when measured in parallel to the intended path as shown in the figure below.

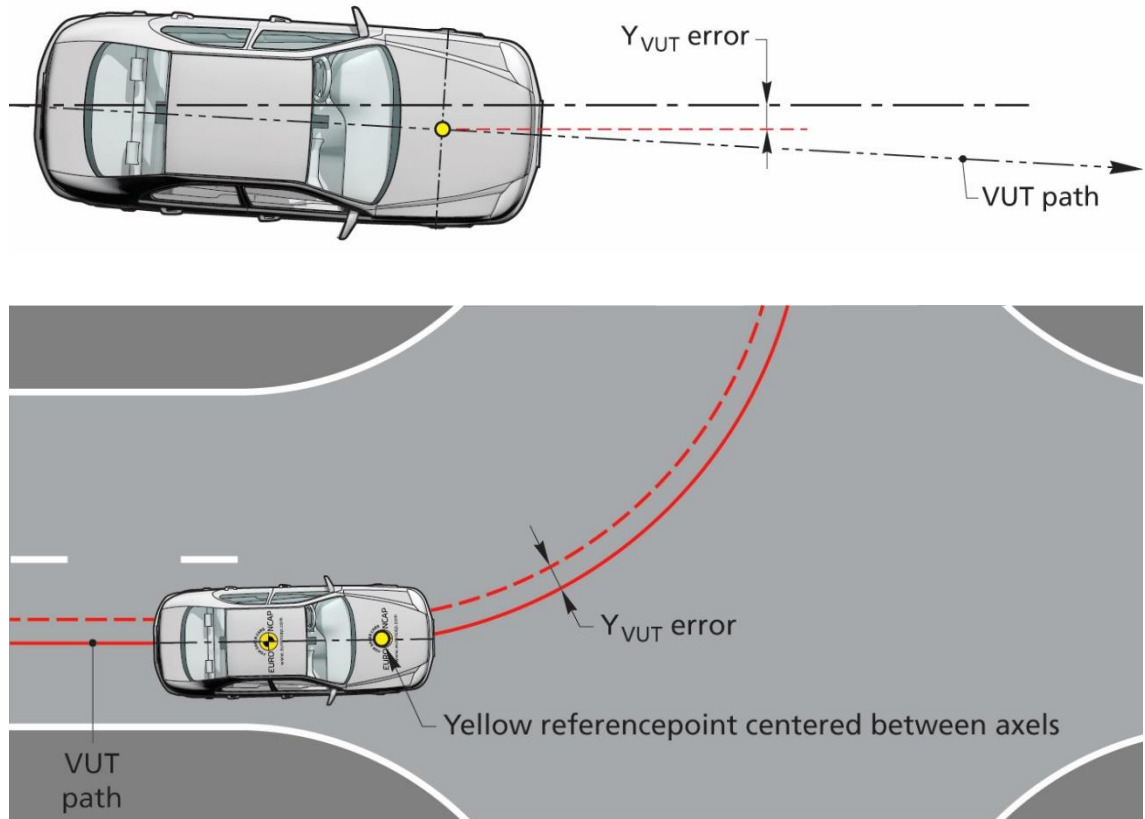

Figure 3-2: Lateral path error

3.3 Profiles for impact speed determination

3.3.1 A virtual profiled line is defined around the front end of the VUT. This line is defined by straight line segments connecting seven points that are equally distributed over the vehicle width minus 50mm on each side. The theoretical x,y coordinates are provided by the OEMs and verified by the test laboratory.

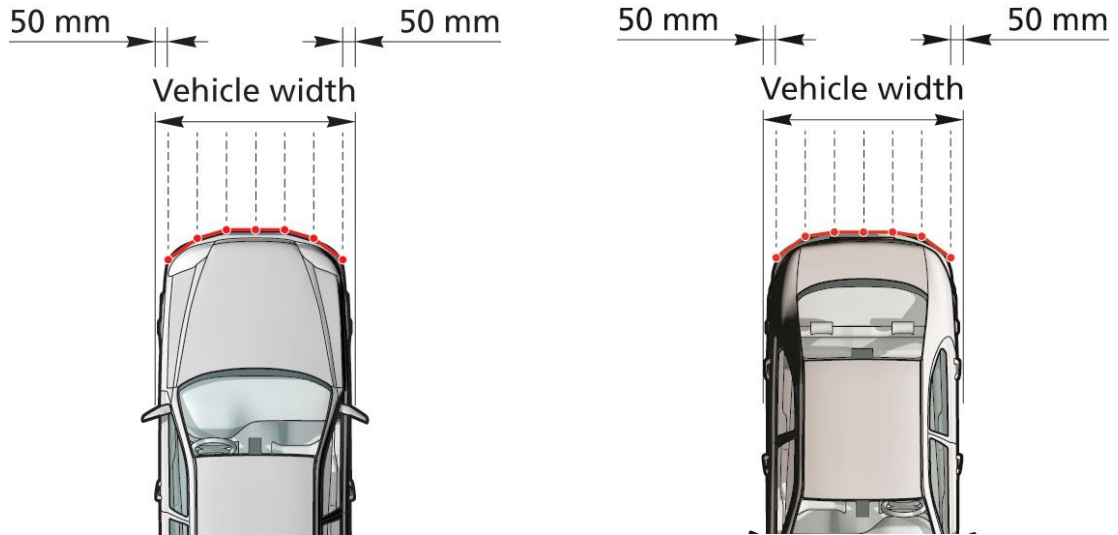

Figure 3-3: Virtual profiled line around vehicle front (left) end and rear end (right)

3.3.2 Around the EPT a virtual box is defined which is used to determine the impact speed. The dimensions of this virtual box are shown in Figure 3-4 below, with reference points on the hip and a virtual point where the centreline of the dummy crosses the virtual box. The scenario descriptions in 7.2 illustrate which of the reference points is used in that scenario.

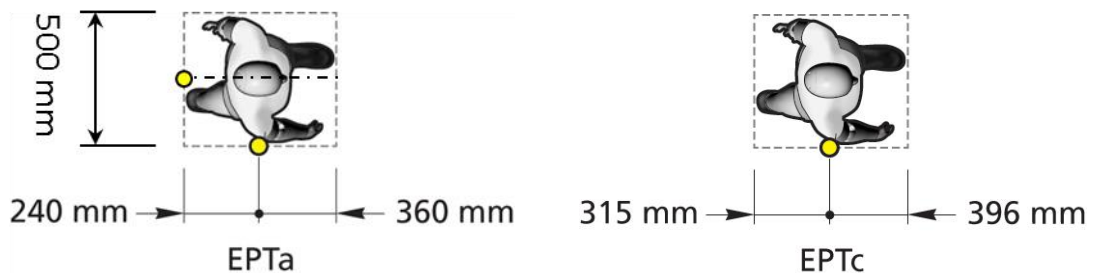

Figure 3-4: Virtual box dimensions around EPTa and EPTc

3.3.3 Around the EBT a virtual box is defined which is used to determine the impact speed. The dimensions of this virtual box are shown in Figure 3-5 below, with reference points on the crank shaft, most forward point on the front wheel and most rearward point on the rear wheel. The scenario descriptions in 7.3 illustrate which of the reference points is used in that scenario.

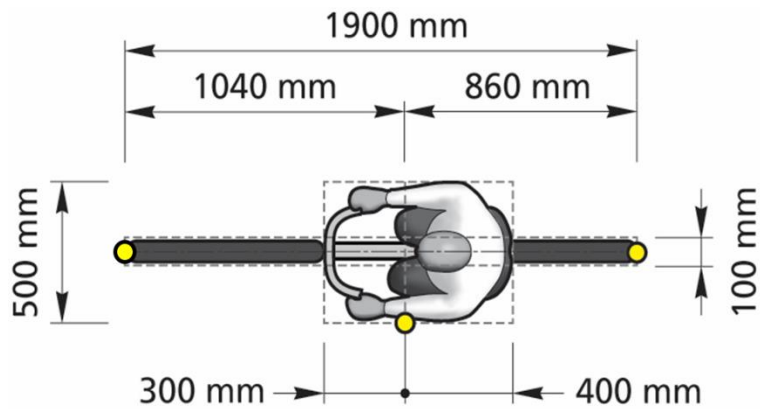

Figure 3-5: Virtual box dimensions around EBT

3.3.4 Around the EMT a virtual box is defined which is used to determine the impact speed. The dimensions of this virtual box are shown in Figure 3-6 below with reference points on the side midposition, most forward point on the front wheel and most rearward point on the rear wheel. The scenario descriptions in 7.4 illustrate which of the reference points is used in that scenario.

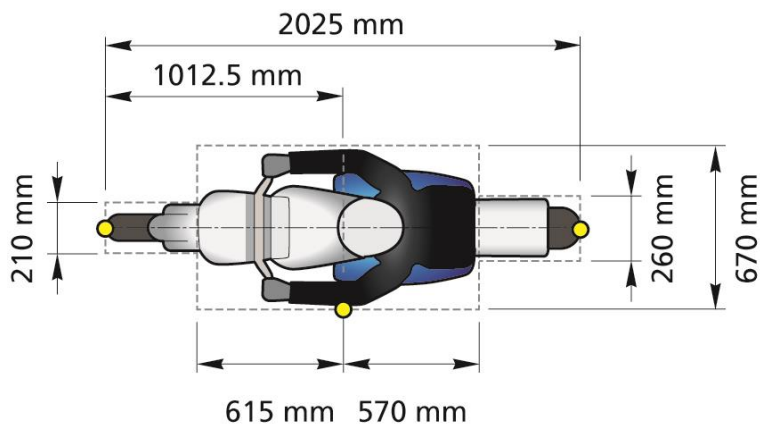

Figure 3-6: Virtual box dimensions around EMT

4 MEASURING EQUIPMENT

4.1.1 Sample and record all dynamic data at a frequency of at least 100Hz. Synchronise the VRU target data with that of the VUT using the DGPS time stamp.

4.2 Measurements and Variables

4.2.1	Time	T
	• T_0 equals TTC = 4s	T₀
	• T_{AEB} , time where AEB activates	T_{AEB}
	• T_{FCW} , time where FCW activates	T_{FCW}
	• T_{impact} , time where VUT impacts the target	T_{impact}
	• T_{steer} , time where VUT enters in curve segment	T_{steer}
	• T_{open} , time where VUT driver door handle is operated	T_{open}
4.2.2	Position of the VUT during the entire test	X_{VUT}, Y_{VUT}
4.2.3	Position of the target during the entire test	
	• for crossing scenarios	Y_{target}
	• for longitudinal scenarios	X_{target}
4.2.4	Speed of the VUT during the entire test	V_{VUT}
	• V_{impact} , speed when VUT impacts the target	V_{impact}
4.2.5	Speed of the target during the entire test	V_{target}
4.2.6	Yaw velocity of the VUT during the entire test	Ψ_{VUT}
4.2.7	Yaw velocity of the target during the entire test	Ψ_{target}
4.2.8	Longitudinal acceleration of the VUT during the entire test	A_{VUT}
4.2.9	Longitudinal acceleration of the EMT during the entire test	A_{target}
4.2.10	Steering wheel velocity of the VUT during the entire test	Ω_{VUT}

4.3 Measuring Equipment

4.3.1 Equip the VUT and the VRU target (where self-propelling platforms are used) with data measurement and acquisition equipment to sample and record data with an accuracy of at least:

- VUT and target speed to 0.1km/h;
- VUT and target lateral and longitudinal position to 0.03m;
- VUT heading angle to 0.1°;
- VUT and target yaw rate to 0.1°/s;
- VUT and target longitudinal acceleration to 0.1m/s²;
- VUT steering wheel velocity to 1.0 °/s.

4.4 Data Filtering

4.4.1 Filter the measured data as follows:

4.4.1.1 Position and speed are not filtered and are used in their raw state.

4.4.1.2 Acceleration, yaw rate and VUT steering wheel velocity with a 12-pole phaseless Butterworth filter with a cut off frequency of 10Hz.

5 EURO NCAP VULNERABLE ROAD USER TARGETS

5.1 Specification

5.1.1 Conduct the tests in this protocol using the Euro NCAP Pedestrian Target (EPTa and EPTc), Euro NCAP Bicyclist Target (EBT) and Euro NCAP Motorcyclist Target (EMT) dressed in a black shirt and blue trousers, as shown in Figure 5-1 below. The EPT, EBT and EMT replicate the visual, radar, LIDAR and PMD attributes of a typical pedestrian, bicyclist and motorcyclist respectively, and is impactable without causing significant damage to the VUT.



Figure 5-1: Euro NCAP VRU Targets (EPTa, EPTc, EBT and EMT)

To ensure repeatable results the propulsion system and VRU target must meet the requirements as detailed in ISO 19206 Road vehicles — Test devices for target vehicles, vulnerable road users and other objects, for assessment of active safety functions

- Part 2:2018: Requirements for pedestrian targets (articulated only)
- Part 4:2018: Requirements for bicyclist targets
- Part 5 (Draft): Requirements for Motorcyclist targets (including Micro-Doppler)

5.1.2 The VRU targets are designed to work with the following types of sensors:

- Radar (24 and 76-81 GHz)
- LIDAR
- Camera
- Ultrasonic sensors

When a manufacturer believes that any of the VRU targets is not suitable for another type of sensor system used by the VUT but not listed above, the manufacturer is asked to contact the Euro NCAP Secretariat.

6 TEST CONDITIONS

6.1 Test Track

6.1.1 Conduct tests on a dry (no visible moisture on the surface), uniform, solid-paved surface with a consistent slope between level and 1%. The test surface shall have a minimal peak braking coefficient (PBC) of 0.9.

6.1.2 The surface must be paved and may not contain any irregularities (e.g. large dips or cracks, manhole covers or reflective studs) that may give rise to abnormal sensor measurements within a lateral distance of 3.0m to either side of the test path and with a longitudinal distance of 30m ahead of the VUT when the test ends.

6.1.3 The presence of lane markings is allowed. However, testing may only be conducted in an area where typical road markings depicting a driving lane may not be parallel to the test path within 3.0m either side. Lines or markings may cross the test path, but may not be present in the area where AEB activation and/or braking after FCW is expected.

6.1.4 Junction and Lane Markings

6.1.4.1 Some scenarios described in this document require the use of a junction, where this is the case the scenario description will illustrate the scenario on a junction as in Figure 6-1. The main approach lane where the VUT path starts, (horizontal lanes in Figure 6-1) will have a width of 3.5m. The side lane (vertical lanes in Figure 6-1) will have a width of 3.25 to 3.5m. The lane markings on these lanes need to conform to one of the lane markings as defined in UNECE Regulation 130:

1. Dashed line starting at the same point where the radius transitions into a straight line with a width between 0.10 and 0.15m
2. Solid line with a width between 0.10 and 0.25m
3. Junction without any central markings

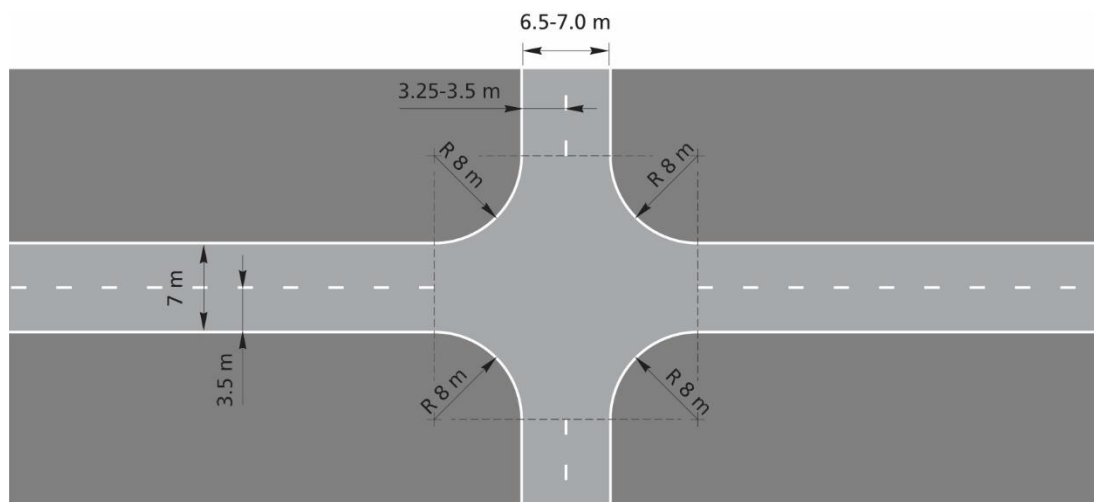

Figure 6-1: Layout of junction and the connecting lanes

6.2 Weather Conditions

- 6.2.1 Conduct tests in dry conditions with ambient temperature above 5°C and below 40°C. For night time tests, the lab may liaise with the OEM to be able to test at lower temperatures.
- 6.2.2 No precipitation shall be falling and horizontal visibility at ground level shall be greater than 1km. Wind speeds shall be below 10m/s to minimise VRU target and VUT disturbance. In case of wind speeds above 5m/s during test the validity of the tests is decided by lab discretion using the OEM predicted performance.
- 6.2.3 For daytime testing, natural ambient illumination must be homogenous in the test area and in excess of 2000 lux for daylight testing with no strong shadows cast across the test area other than those caused by the VUT or VRU target. Ensure testing is not performed driving towards, or away from the sun when there is direct sunlight.
- 6.2.4 Testing at low ambient lighting conditions, night time, are specified in ANNEX B.
- 6.2.5 Measure and record the following parameters preferably at the commencement of every single test or at least every 30 minutes:
 - a) Ambient temperature in °C;
 - b) Track Temperature in °C;
 - c) Wind speed and direction in m/s;
 - d) Ambient illumination in Lux.

6.3 Surroundings

- 6.3.1 Conduct testing such that there are no other vehicles, highway infrastructure (except lighting columns during the low ambient lighting condition tests), obstructions, other objects or persons protruding above the test surface, within 4m of the vehicle path, that may give rise to abnormal sensor measurements during the full duration of the test and within a longitudinal distance of 30m ahead of the VUT when the test ends.
- 6.3.2 Test areas where the VUT needs to pass under overhead signs, bridges, gantries or other significant structures are not permitted.
- 6.3.3 The general view ahead and to either side of the test area shall comprise of a wholly plain man made or natural environment (e.g. further test surface, plain coloured fencing or hoardings, natural vegetation or sky etc.) and must not comprise any highly reflective surfaces or contain any vehicle-like silhouettes that may give rise to abnormal sensor measurements.

6.4 VUT Preparation

6.4.1 AEB and FCW System Settings

- 6.4.1.1 Set any driver configurable elements of the AEB and/or FCW system (e.g. the timing of the collision warning or the braking application if present) to the middle setting or midpoint and then next latest setting similar to the examples shown in Figure 6-2.

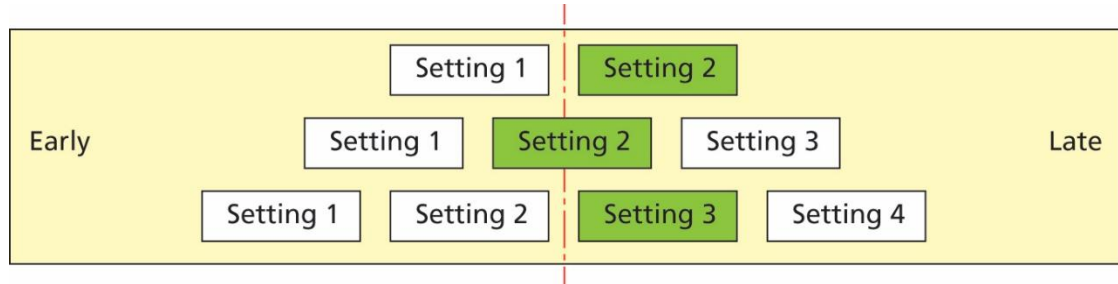

Figure 6-2: AEB and/or FCW system setting for testing

6.4.2 Deployable Pedestrian/VRU Protection Systems

When the vehicle is equipped with a deployable pedestrian/VRU protection system, this system shall be deactivated before the testing commences.

6.4.3 Tyres

Perform the testing with new original fitment tyres of the make, model, size, speed and load rating as specified by the vehicle manufacturer. It is permitted to change the tyres which are supplied by the manufacturer or acquired at an official dealer representing the manufacturer if those tyres are identical make, model, size, speed and load rating to the original fitment. Use inflation pressures corresponding to least loading normal condition.

Run-in tyres according to the tyre conditioning procedure specified in 7.1.3. After running-in maintain the run-in tyres in the same position on the vehicle for the duration of the testing.

6.4.4 Wheel Alignment Measurement

The vehicle should be subject to a vehicle (in-line) geometry check to record the wheel alignment set by the OEM. This should be done with the vehicle in kerb weight.

6.4.5 Unladen Kerb Mass

- 6.4.5.1 Fill up the tank with fuel to at least 90% of the tank's capacity of fuel.
- 6.4.5.2 Check the oil level and top up to its maximum level if necessary. Similarly, top up the levels of all other fluids to their maximum levels if necessary.
- 6.4.5.3 Ensure that the vehicle has its spare wheel on board, if fitted, along with any tools supplied with the vehicle. Nothing else should be in the car.
- 6.4.5.4 Ensure that all tyres are inflated according to the manufacturer's instructions for the least loading condition.
- 6.4.5.5 Measure the front and rear axle masses and determine the total mass of the vehicle. The total mass is the 'unladen kerb mass' of the vehicle. Record this mass in the test details.
- 6.4.5.6 Calculate the required ballast mass, by subtracting the mass of the test driver and test equipment from the required 200 kg interior load.

6.4.6 Vehicle Preparation

- 6.4.6.1 Fit the on-board test equipment and instrumentation in the vehicle. Also, fit any associated cables, cabling boxes and power sources.
- 6.4.6.2 Place weights with a mass of the ballast mass. Any items added should be securely attached to the car.
- 6.4.6.3 With the driver in the vehicle, weigh the front and rear axle loads of the vehicle.
- 6.4.6.4 Compare these loads with the "unladen kerb mass"
- 6.4.6.5 The total vehicle mass shall be within $\pm 1\%$ of the sum of the unladen kerb mass, plus 200kg. The front/rear axle load distribution needs to be within 5% of the front/rear axle load distribution of the original unladen kerb mass plus full fuel load. If the vehicle differs from the requirements given in this paragraph, items may be removed or added to the vehicle which has no influence on its performance. Any items added to increase the vehicle mass should be securely attached to the car.
- 6.4.6.6 Repeat paragraphs 6.4.6.3 and 6.4.6.4 until the front and rear axle loads and the total vehicle mass are within the limits set in paragraph 6.4.6.5. Care needs to be taken when adding or removing weight in order to approximate the original vehicle inertial properties as close as possible. Record the final axle loads in the test details. Record the axle weights of the VUT in the 'as tested' condition.
- 6.4.6.7 Verify the x-y coordinates for the virtual front end vehicle contour given by the manufacturer. When the coordinates given are within 10mm of those measured by the test laboratory, the coordinates as provided by the manufacturer will be used. When the coordinates are not within 10mm, the coordinates as measured by the laboratory will be used.

7 TEST PROCEDURE

7.1 VUT Pre-test Conditioning

7.1.1 General

7.1.1.1 A new car is used as delivered to the test laboratory.

7.1.1.2 If requested by the vehicle manufacturer, drive a maximum of 100km on a mixture of urban and rural roads with other traffic and roadside furniture to ‘calibrate’ the sensor system. Avoid harsh acceleration and braking.

7.1.2 Brakes

7.1.2.1 Condition the vehicle’s brakes in the following manner, if it has not been done before or in case the lab has not performed a 100km of driving:

- Perform twenty stops from a speed of 56km/h with an average deceleration of approximately 0.5 to 0.6g.
- Immediately following the series of 56km/h stops, perform three additional stops from a speed of 72km/h, each time applying sufficient force to the pedal to operate the vehicle’s antilock braking system (ABS) for the majority of each stop.
- Immediately following the series of 72km/h stops, drive the vehicle at a speed of approximately 72km/h for five minutes to cool the brakes.

7.1.3 Tyres

7.1.3.1 Condition the vehicle’s tyres in the following manner to remove the mould sheen, if this has not been done before for another test or in case the lab has not performed a 100km of driving:

- Drive around a circle of 30m in diameter at a speed sufficient to generate a lateral acceleration of approximately 0.5 to 0.6g for three clockwise laps followed by three anticlockwise laps.
- Immediately following the circular driving, drive four passes at 56km/h, performing ten cycles of a sinusoidal steering input in each pass at a frequency of 1Hz and amplitude sufficient to generate a peak lateral acceleration of approximately 0.5 to 0.6g.
- Make the steering wheel amplitude of the final cycle of the final pass double that of the previous inputs.

7.1.3.2 In case of instability in the sinusoidal driving, reduce the amplitude of the steering input to an appropriately safe level and continue the four passes.

7.1.4 AEB/FCW System Check

7.1.4.1 Before any testing begins, perform a maximum of ten runs at the lowest test speed the system is supposed to work, to ensure proper functioning of the system.

7.2 Car-to-Pedestrian Scenarios

The performance of the system is assessed in different scenarios. For AEB Pedestrian the scenarios are considered in these sections:

	CPFA	CPNA	CPNCO	CPLA		CPTA		CPRA/CPRC	
Section	0	7.2.2	7.2.3	7.2.4		7.2.5		0	
Type of test	AEB			AEB	FCW/ESS	AEB		AEB	
VUT speed [km/h]	10-60			20-60	50-80	10,15,20	10	4,8	
VUT direction	Forward			Forward		Farside turn	Nearside turn	Rearward	
Target speed [km/h]	8	5		5	5	5		0	5
Target direction	From farside	From Nearside		Forward		Farside/Nearside after turn		Stationary	Farside/Nearside
Impact location [%]	50	25,75*	50	50	25	50		25,50,75	50
Lighting condition	Day/Night			Day/Night		Day		Day	
Vehicle lights (night)	Low beam			High beam					
Streetlights (night)	Streetlights			No streetlights					

*For the CPNA-75 scenario an additional test during day- and nighttime is performed as part of the prerequisite verification at a test speed of 20km/h and with an EPTa speed of 3 km/h

7.2.1 Car-to-Pedestrian Farside Adult

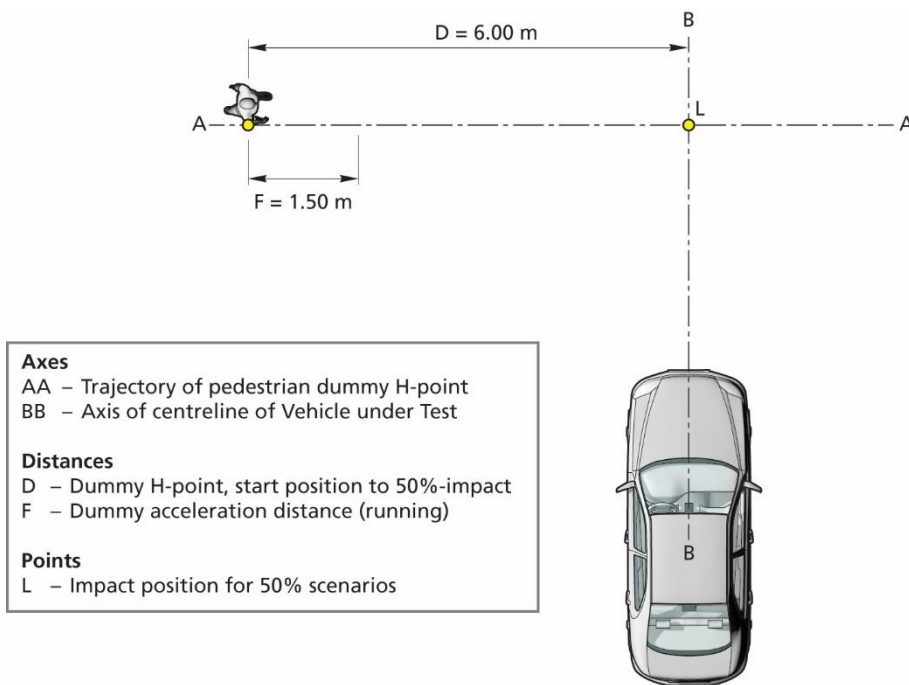

Figure 7-1: CPFA-50 scenario, Adult running from Farside

7.2.2 Car-to-Pedestrian Nearside Adult

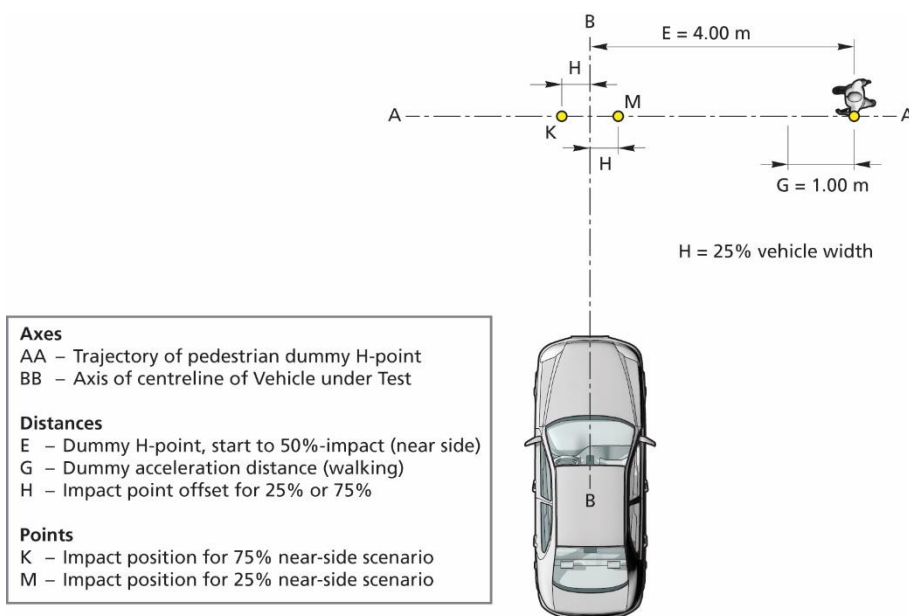

Figure 7-2: CPNA-25 & CPNA-75 scenarios, Walking Adult from Nearside

7.2.3 Car-to-Pedestrian Nearside Child

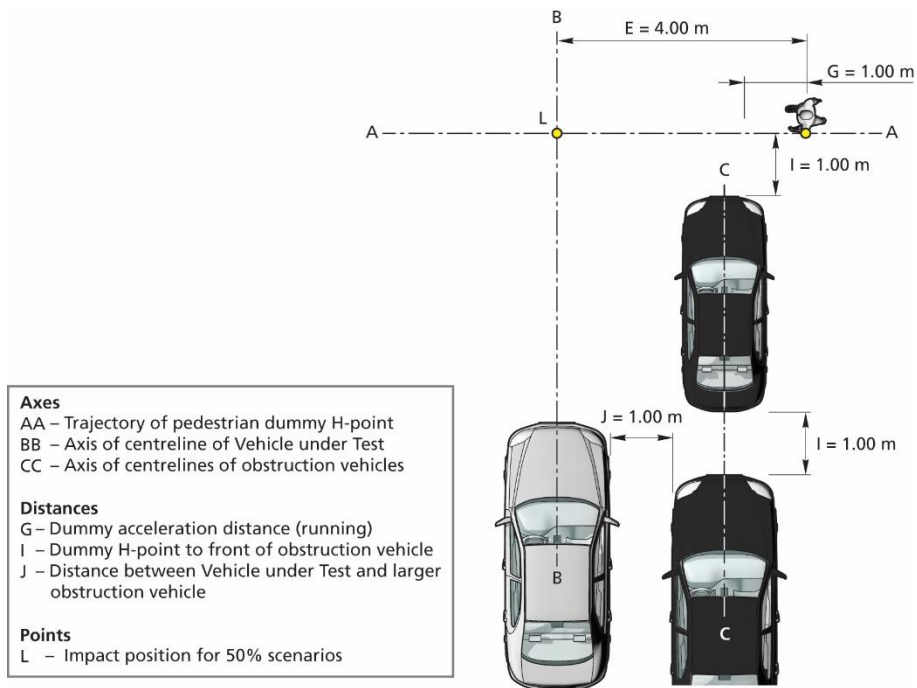

Figure 7-3: CPNCO-50 scenario, Running Child from Nearside from Obstruction (Annex A)

7.2.4 Car-to-Pedestrian Longitudinal Adult

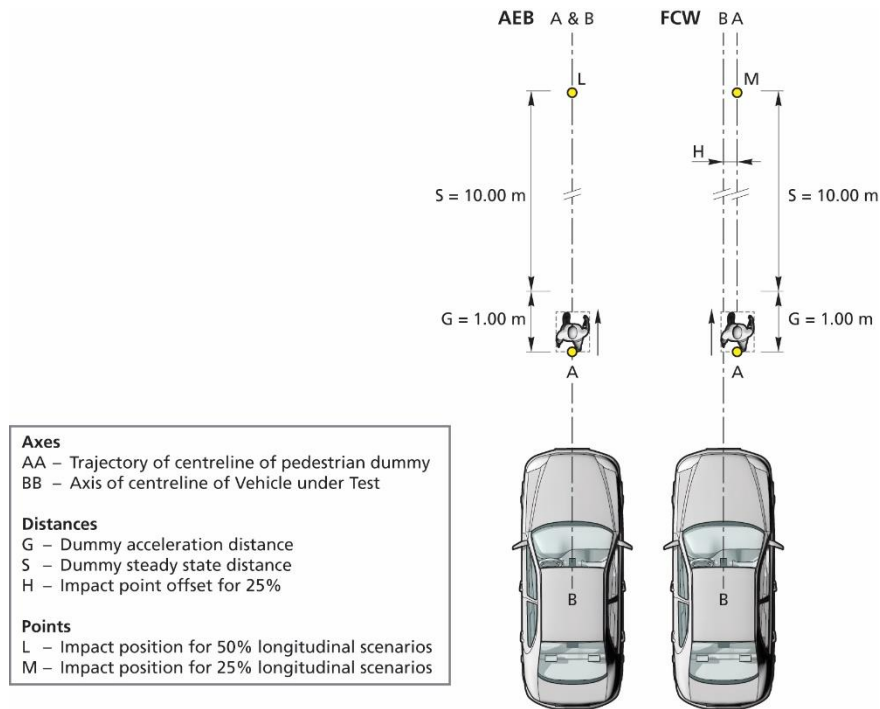

Figure 7-4: CPLA scenario, Longitudinal walking Adult

7.2.5 Car-to-Pedestrian Turning Adult

For the CPTA scenarios, for the VUT assume an initial straight-line path followed by a turn (clothoid, fixed radius and clothoid as specified in section 7.2.5.1), followed again by a straight line, hereby known as the test path.

The VUT will follow a straight-line path in the approach lane which will be 1.75m from the centre of the centre dashed lane marking of the VUT lane.

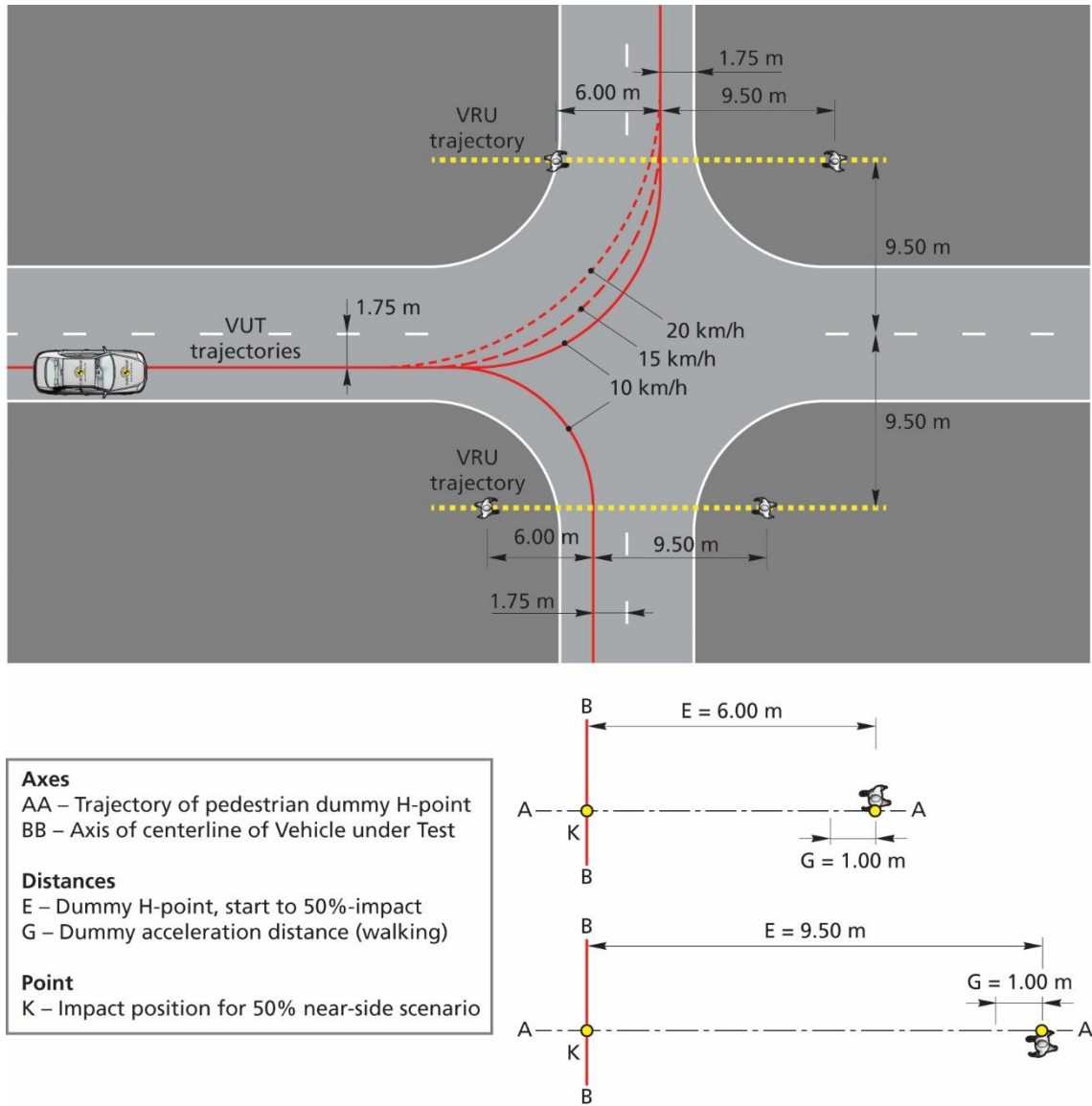
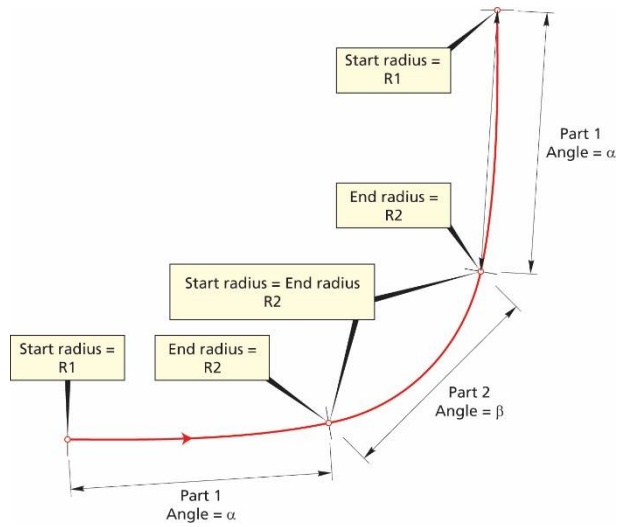

Figure 7-5: CPTA scenarios, Turning walking Adult

7.2.5.1 The following parameters should be used to create the test paths. The tests are performed without using the turn signal:



Test speed	Part 1 (clothoid)			Part 2 (constant radius)			Part 3 (clothoid)		
	Start Radius R1 [m]	End Radius R2 [m]	Angle α [deg]	Start Radius R2 [m]	End Radius R2 [m]	Angle β [deg]	Start Radius R2 [m]	End Radius R1 [m]	Angle α [deg]
10 km/h to Farside	1500	9.00	20.62	9.00	9.00	48.76	9.00	1500	20.62
15 km/h to Farside	1500	11.75	20.93	11.75	11.75	48.14	11.75	1500	20.93
20 km/h to Farside	1500	14.75	21.79	14.75	14.75	46.42	14.75	1500	21.79
10 km/h to Nearside	1500	8.00	22.85	8.00	8.00	44.30	8.00	1500	22.85

7.2.6 Car-to-Pedestrian Reverse Adult/Child

In the Car-to-Pedestrian Reverse scenario, a combination of the EPTa and EPTc is used to ensure robust performance. The following table shows which of the pedestrian targets is used in the different speed and overlap combinations.

Speed	Overlap	CPRs	CPRm
4 km/h	25%	EPTc	
	50%	EPTa	EPTa
	75%	EPTc	
8 km/h	25%	EPTa	
	50%	EPTc	EPTc
	75%	EPTa	

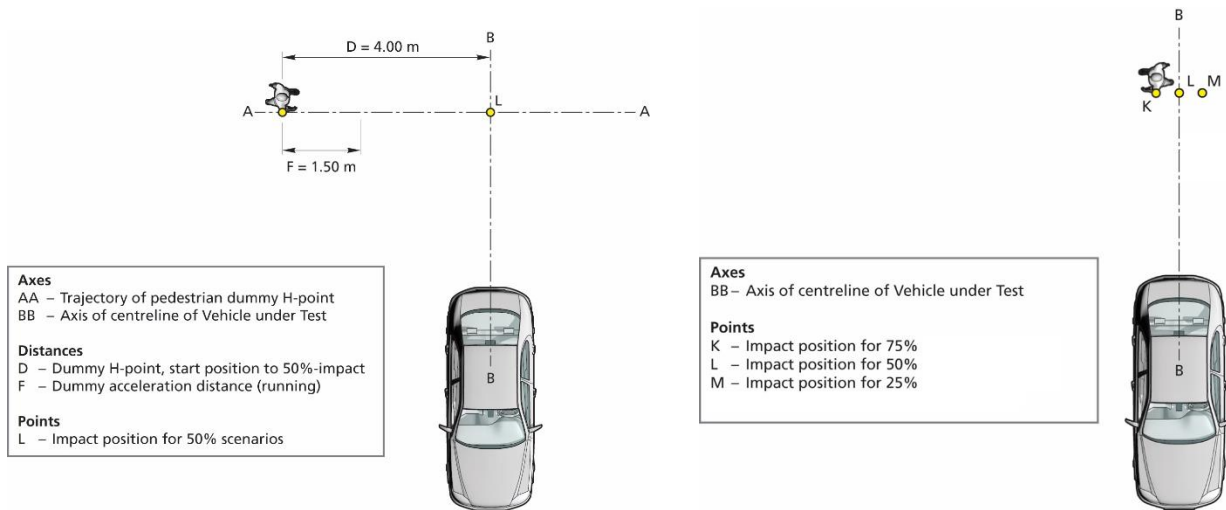

Figure 7-6: CPRA/CPRC scenario, Pedestrian from Nearside (right) and Stationary (left)

7.3.2 Car-to-Bicyclist Nearside Adult

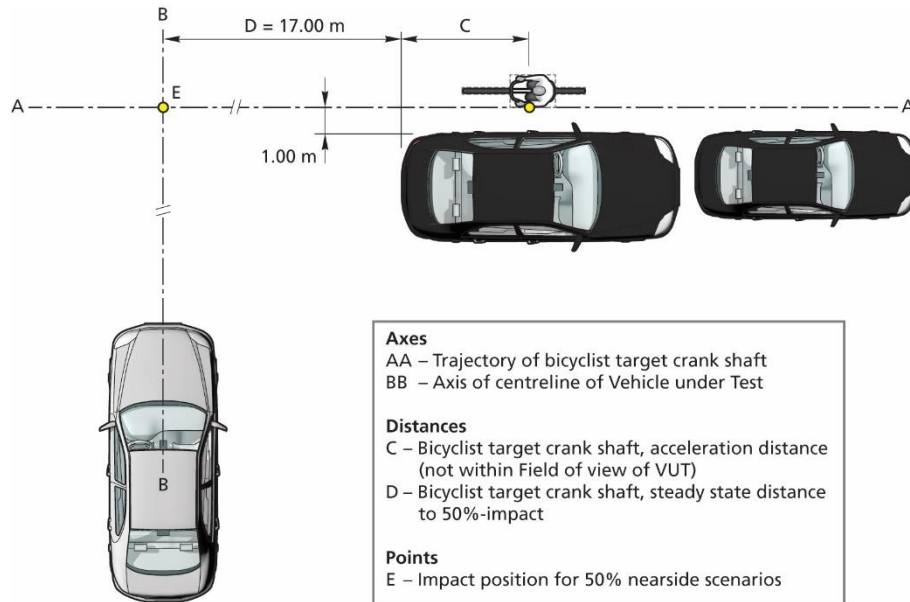

Figure 7-8: CBNA scenario, Bicyclist from Nearside

7.3.3 Car-to-Bicyclist Nearside Adult Obstructed

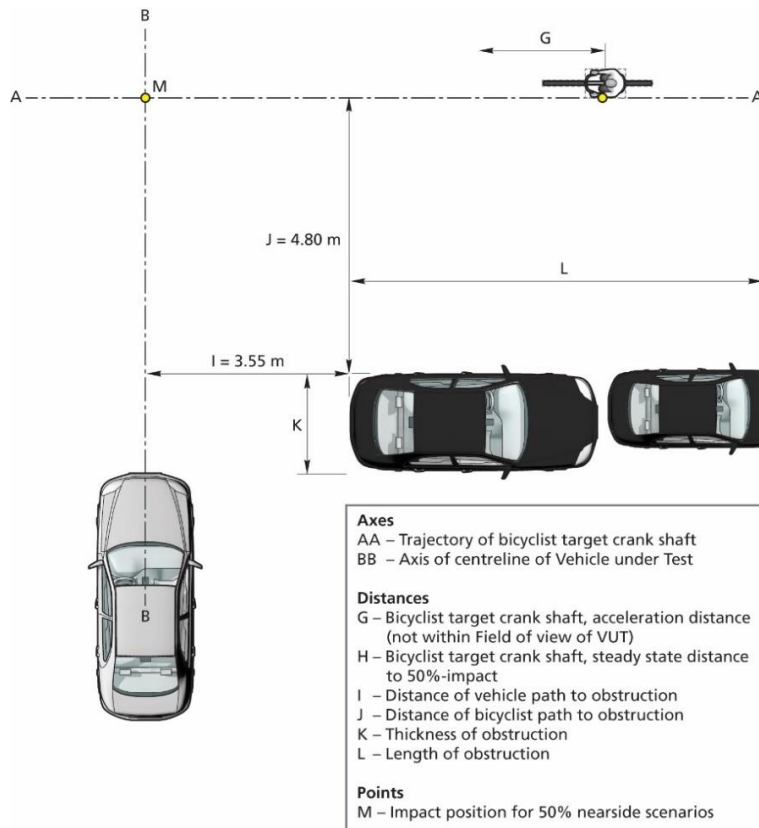

Figure 7-9: CBNAO scenario, Bicyclist from Nearside (obstructed)

7.3.4 Car-to-Bicyclist Longitudinal Adult

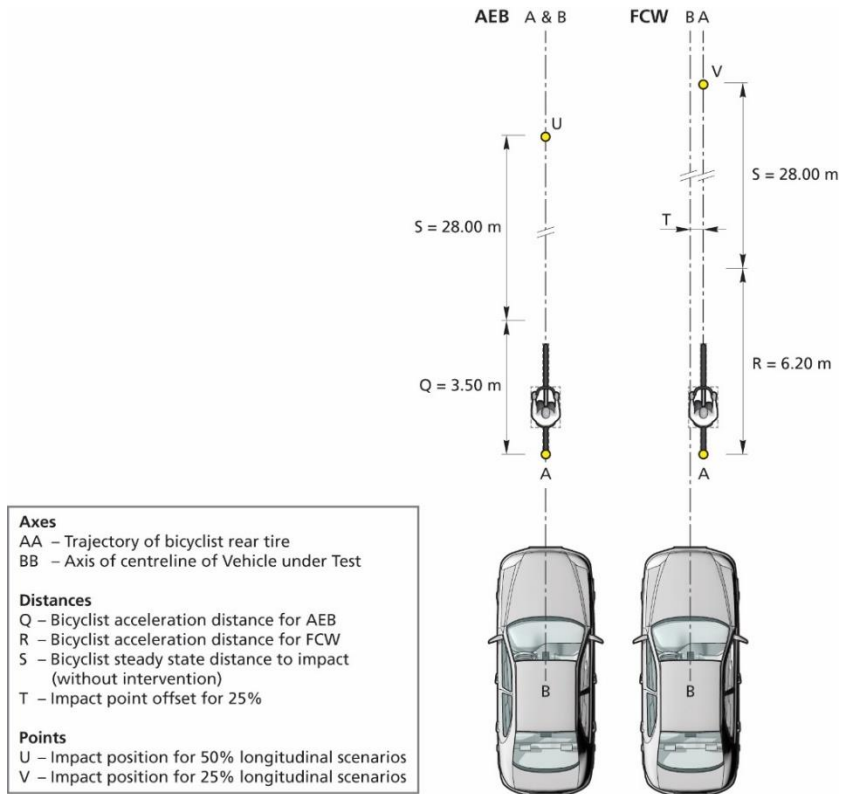

Figure 7-10: CBLA scenarios, Longitudinal Bicyclist (AEB left & FCW right)

7.3.5 Car-to-Bicyclist Turning Adult

For the CBTA scenarios, for the VUT assume an initial straight-line path followed by a turn (clothoid, fixed radius and clothoid as specified in section 7.2.5.1), followed again by a straight line, hereby known as the test path. The direction indicator is applied at 1.0s before T_{STEER} .

The VUT will follow a straight-line path in the approach lane which will be 1.75m from the centre of the centre dashed lane marking of the VUT lane. The EBT will follow a straight-line path which will be respectively 2.75m (farside turn) and 5.00m (nearside turn) from the centre of the centre dashed lane marking of the VUT lane. Steady state speed of EBT starts at 4sec TTC.

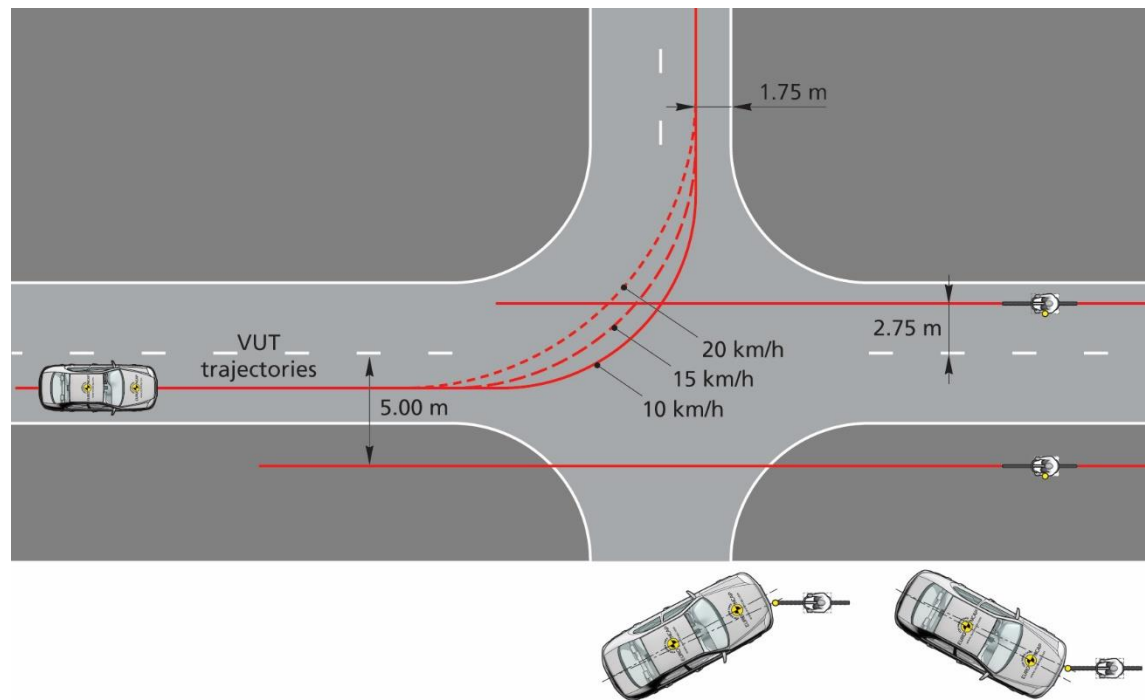

Figure 7-11: CBTA scenarios, Turning cycling Adult

7.3.6 Car-to-Bicyclist Dooring

For the CBDA scenario a bicycle is traveling in a straight line at 15 km/h beside the parked vehicle. In the first run, the EBT passes the parking car without operation on the door handle to assess the information given to the driver, where applicable.

In the second run (when applicable), the VUT driver door handle will be operated when the bicyclist front reference point is @ $7\text{m} \pm [0.5]$ m from the most rearward point of the driver door.



Figure 7-12: Reference point and direction relative to the VUT for dooring scenario

Door opening (manually operated):

Pull door handle or activate other door opening interface (e.g. push a button) in a manner that would open the door to exit the car in a normal non-hazard situation, while pushing the door open. Emergency exit functions may be available but need an additional action to be triggered (e.g. second pull).

For CBDA, all tests shall be performed with the VUT in parking position within 60 seconds (180 seconds from 2025 onwards) after engine and ignition turned off.

The obstruction vehicle to be used is the smaller obstruction vehicle as defined in Appendix A.1.

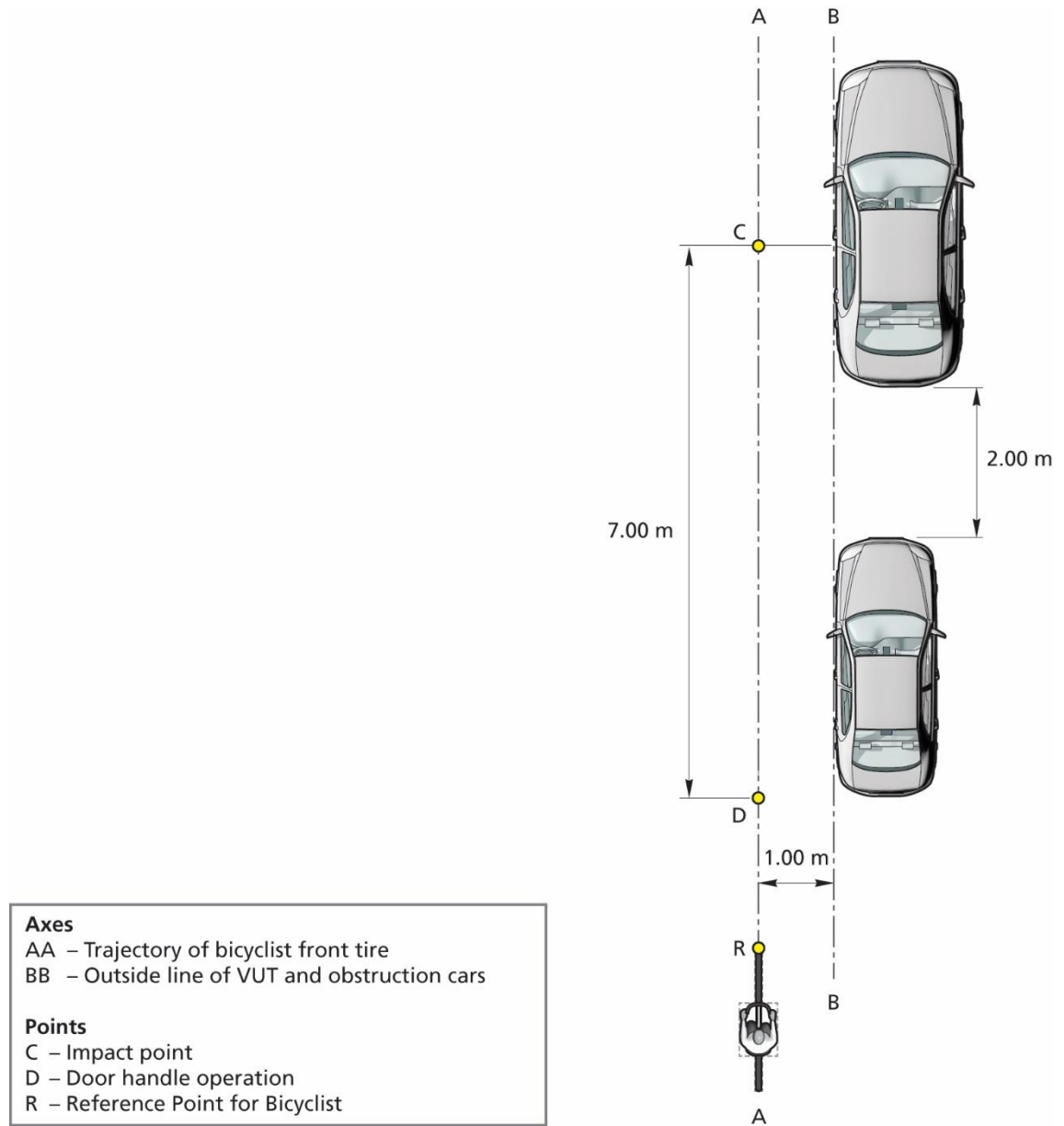

Figure 7-13 CBDA scenarios, Dooring cycling Adult

7.4 Car-to-Motorcyclist Scenarios

For AEB/LSS Motorcyclist the scenarios are considered in these sections:

	CMRs		CMRb	CMFtap	CMoncoming	CMovertaking
Paragraph	7.4.1		0	0	0	0
Type of test	AEB	FCW	AEB/FCW	AEB	LSS	LSS
VUT speed [km/h]	10-60	30-60	50	10,15,20	72	50,72
VUT direction	Forward		Forward	Farside turn	Farside	Farside
Target speed [km/h]	0		50	30,45,60	72	60,80
Impact location [%]	50		25	50	10	Rear wheel
Lighting condition	Day		Day	Day	Day	Day

7.4.1 Car-to-Motorcyclist Rear stationary

The CMRs scenario will be performed with 5km/h incremental steps in speed within the ranges and 50% in overlap as shown in the tables below.

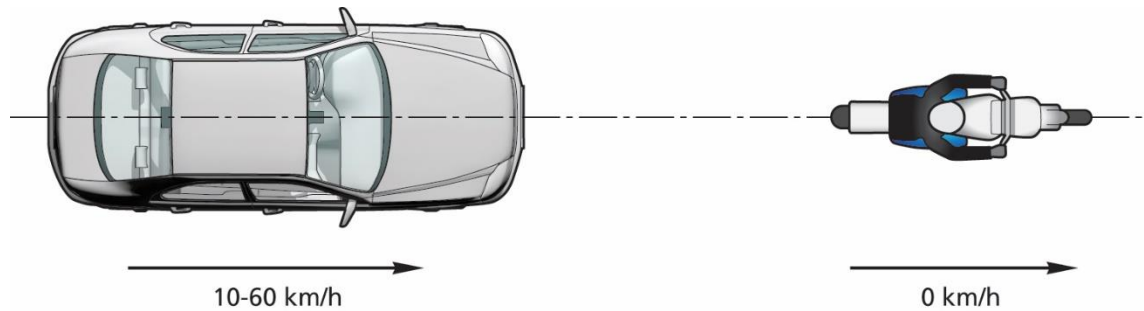

Figure 7-14: CMRs scenario

7.4.2 Car-to-Motorcyclist Rear braking

The CMRb tests will be performed at a fixed speed of 50km/h for both VUT and EMT with -4m/s^2 EMT acceleration and 12 and 40m headway. In addition, these tests will be performed with 25% in overlap as shown on the figure below.

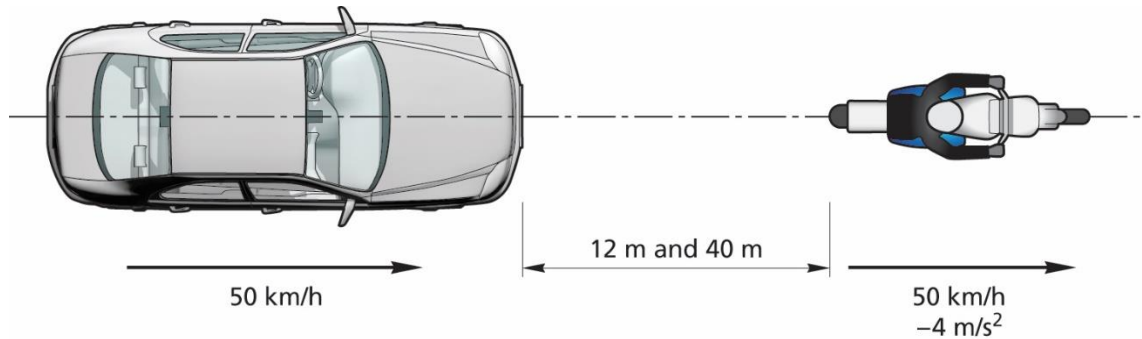

Figure 7-15: CMRb scenario

The desired deceleration of the EMT shall be reached within [0.2] seconds ($T_0 + 1.0\text{s}$) which after the EMT shall remain within $\pm 0.5 \text{ km/h}$ of the reference speed profile, derived from the desired deceleration, until the vehicle speed equals 1 km/h.

7.4.3 Car-to-Motorcyclist Front turn across path

7.4.3.1 For the CMFtap scenario, for the VUT assume an initial straight-line path followed by a turn (clothoid, fixed radius and clothoid as specified in section 7.2.5.1), followed again by a straight line, hereby known as the test path.

7.4.3.2 The EMT will follow a straight-line path in the lane adjacent to the VUT's initial position, in the opposite direction to the VUT. The straight-line path of the VUT and target will be 1.75m from the inner side of the centre dashed lane marking of the VUT lane.

7.4.3.3 The paths of the VUT and EMT will be synchronised so that the front reference point of the EMT impacts the VUT at 50% overlap, assuming no system reaction.

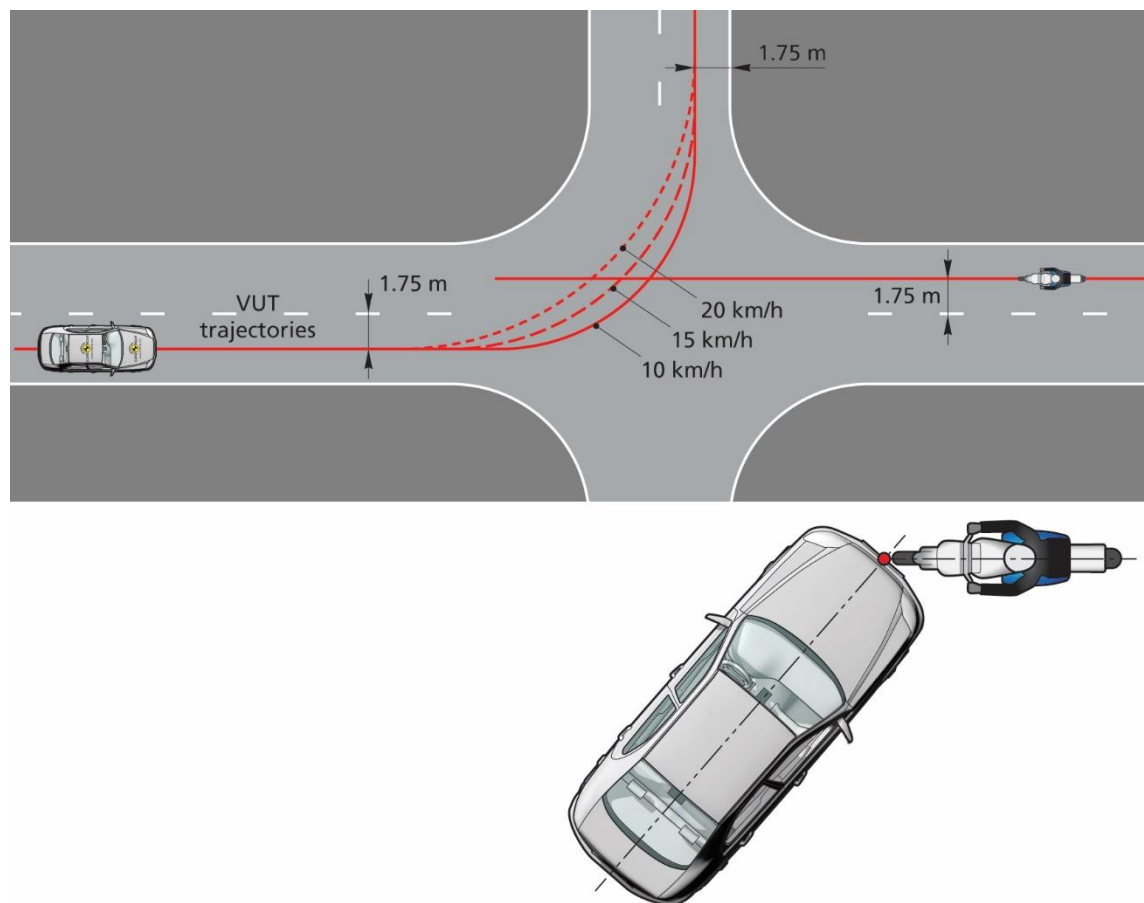

Figure 7-16: CMFtap scenario VUT and EMT paths

7.4.3.4 The CMFtap scenarios are all combinations of VUT speeds of 10, 15 and 20 km/h combined with EMT speeds of 30, 45 and 60 km/h.

7.4.3.5 The parameters given in section 7.2.5.1 should be used to create the test paths where the direction indicator is applied at 1.0s before Tsteer.

7.4.4 Car-to-Motorcyclist oncoming

7.4.4.1 For the oncoming scenario the EMT will follow a straight line path at 72 km/h in the lane adjacent to the VUT's initial position, in the opposite direction to the VUT who also drives at 72 km/h. The straight line path of the target will be 1m for the EMT from the inner side of the centre dashed lane marking of the VUT lane.

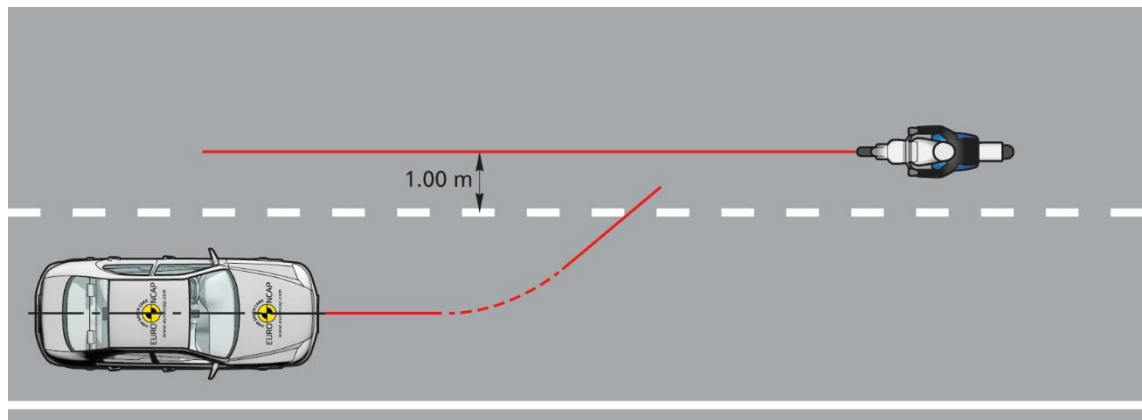

Figure 7-17: CM oncoming vehicle scenario paths

7.4.4.2 The paths of the VUT and EMT will be synchronised so that the front reference point of the EMT impacts the VUT at 10% of the width of the VUT, assuming no system reaction.

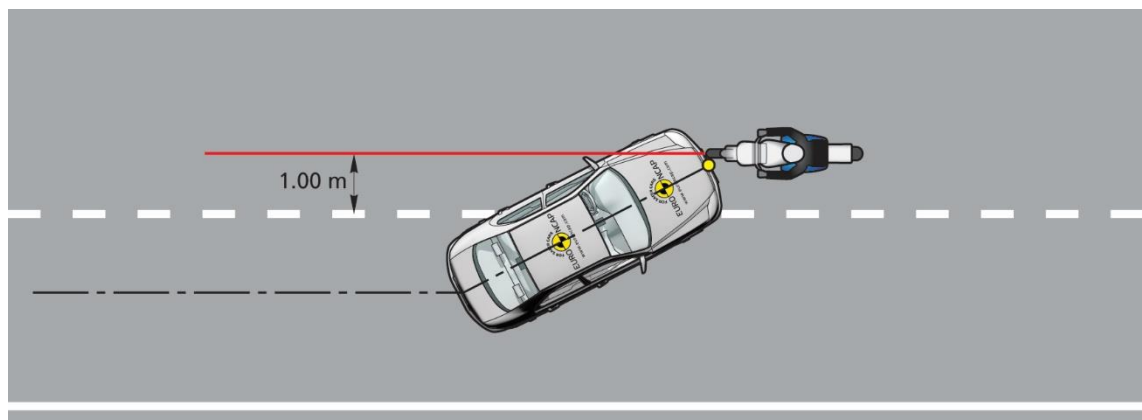

Figure 7-18: CM oncoming motorcycle impact location

7.4.4.3 The following parameters should be used to create the test paths for the tests:

VUT@ 72km/h	V _{latVUT} [m/s]	R [m]	Ψ _{VUT} [°]	d1	d2
Unintentional	0.2	1200	0.57	0.06	0.70
	0.3		0.86	0.14	0.90
	0.4		1.15	0.24	0.80
	0.5		1.43	0.38	0.75
	0.6		1.72	0.54	0.60
Intentional	0.5	800	1.43	0.25	0.75
	0.6		1.72	0.36	0.60
	0.7		2.01	0.49	0.53

Where the lateral offset d from the lane marking:

$$d = d1 + d2 + \text{Half of the vehicle width (m)}$$

With:

d1: Lateral distance travelled during curve establishing yaw angle (m)

d2: Lateral distance travelled during V_{lat} steady state (m)

7.4.4.4 CM oncoming tests will be performed with 0.1 m/s incremental steps within the lateral velocity range of 0.2 to 0.6m/s for departures at the driver side only.

7.4.5 Car-to-Motorcyclist overtaking

- 7.4.5.1 For the overtaking scenario a EMT will follow a straight line path in the lane adjacent to the VUT's initial position at the driver side, in the same direction as the VUT. The straight line path of the target will be 1m for the EMT from the inner side of the centre dashed lane marking.
- 7.4.5.2 The paths of the VUT and EMT will be synchronised so that the longitudinal position of the front reference point of the EMT is equal to that of the rear axle of the VUT at the impact point (assuming no system reaction).
- 7.4.5.3 ELK overtaking vehicle tests will be performed with 0.1m/s incremental steps within the lateral velocity range of 0.2 to 0.6m/s for unintentional lane change and 0.5 to 0.7m/s for intentional lane changes for departures at the driver side only.
- 7.4.5.4 Both unintentional and intentional lane changes are tested in two situations:
- EMT @ 60km/h is overtaking the VUT @ 50km/h (relative velocity of 10km/h)
 - EMT @ 80km/h is overtaking the VUT @ 72km/h (relative velocity of 8km/h)

In case where there is no platform available at the time of protocol introduction, an agreed fallback solution is to be implemented for the EMT @ 80 km/h test. Where the vehicle passes the 60-50 km/h CM overtaking and the 80-72 km/h C2C ELK overtaking test and a BLIS is issued when a real motorcycle overtakes the VUT when driving at the higher test speeds, points should also be awarded.

- 7.4.5.5 For both intentional and unintentional lane changes, the following parameters should be used to create the test paths for the intentional lane change tests where the direction indicator is applied at $1.0s \pm 0.5s$ before T_{STEER} :

VUT@ 50km/h	V_{latVUT} [m/s]	R [m]	Ψ_{VUT} [°]	d1	d2
Unintentional	0.2	1200	0.83	0.12	0.64
	0.3		1.24	0.28	0.76
	0.4		1.65	0.50	0.54
	0.5		2.06	0.78	0.35
	0.6		2.48	1.12	0.02
Intentional	0.5	400	2.06	0.26	0.74
	0.6		2.48	0.37	0.59
	0.7		2.89	0.51	0.51

VUT@ 72km/h	V _{lat} V _{UT} [m/s]	R [m]	Ψ _{VUT} [°]	d1	d2
Unintentional	0.2	1200	0.57	0.06	0.70
	0.3		0.86	0.14	0.90
	0.4		1.15	0.24	0.80
	0.5		1.43	0.38	0.75
	0.6		1.72	0.54	0.60
Intentional	0.5	800	1.43	0.25	0.75
	0.6		1.72	0.36	0.60
	0.7		2.01	0.49	0.53

Where the lateral offset d from the lane marking:

$$d = d1 + d2 + \text{Half of the vehicle width (m)}$$

With:

d1: Lateral distance travelled during curve establishing yaw angle (m)

d2: Lateral distance travelled during V_{lat} steady state (m)

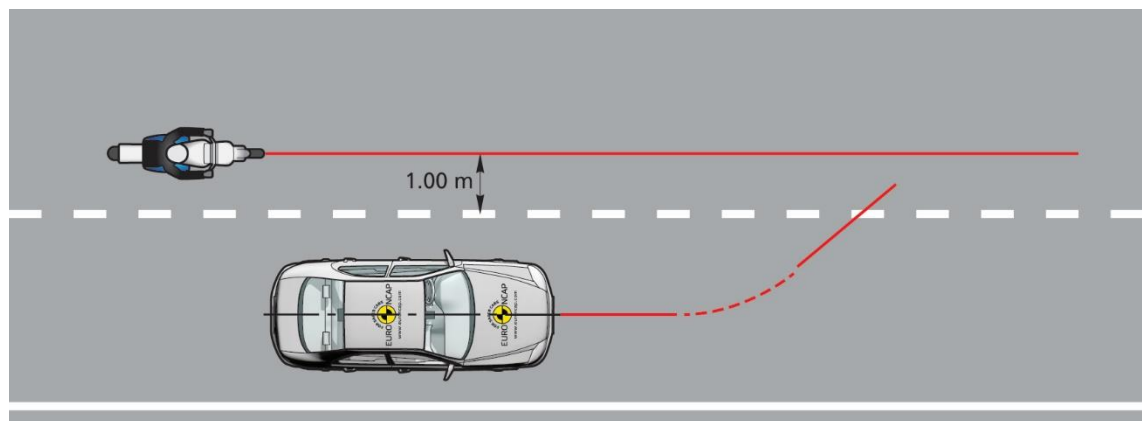

Figure 7-19: CM overtaking scenarios

For intentional lane changes the turn signal should be applied at $1.0s \pm 0.5s$ before T_{STEER} .

7.5 Test Conduct

7.5.1 Before every test run, drive the VUT around a circle of maximum diameter 30m at a speed less than 10km/h for one clockwise lap followed by one anticlockwise lap, and then manoeuvre the VUT into position on the test path. If requested by the OEM an initialisation run may be included before every test run. Bring the VUT to a halt and push the brake pedal through the full extent of travel and release.

7.5.2 For vehicles with an automatic transmission select D. For vehicles with a manual transmission select the highest gear where the RPM will be at least 1500 at the test speed.

7.5.3 Perform the first test a minimum of 90s and a maximum of 10 minutes after completing the tyre conditioning (if applicable), and subsequent tests after the same time period. If the time between consecutive tests exceeds 10 minutes perform three brake stops from 72 km/h at approximately 0.3g.

Between tests, manoeuvre the VUT at a maximum speed of 50km/h and avoid riding the brake pedal and harsh acceleration, braking or turning unless strictly necessary to maintain a safe testing environment.

7.5.4 Based on the OEM colour prediction, the lowest and highest avoidance (Green) test speeds of each scenario (where applicable) will be tested according to the following colourscheme per test speed:

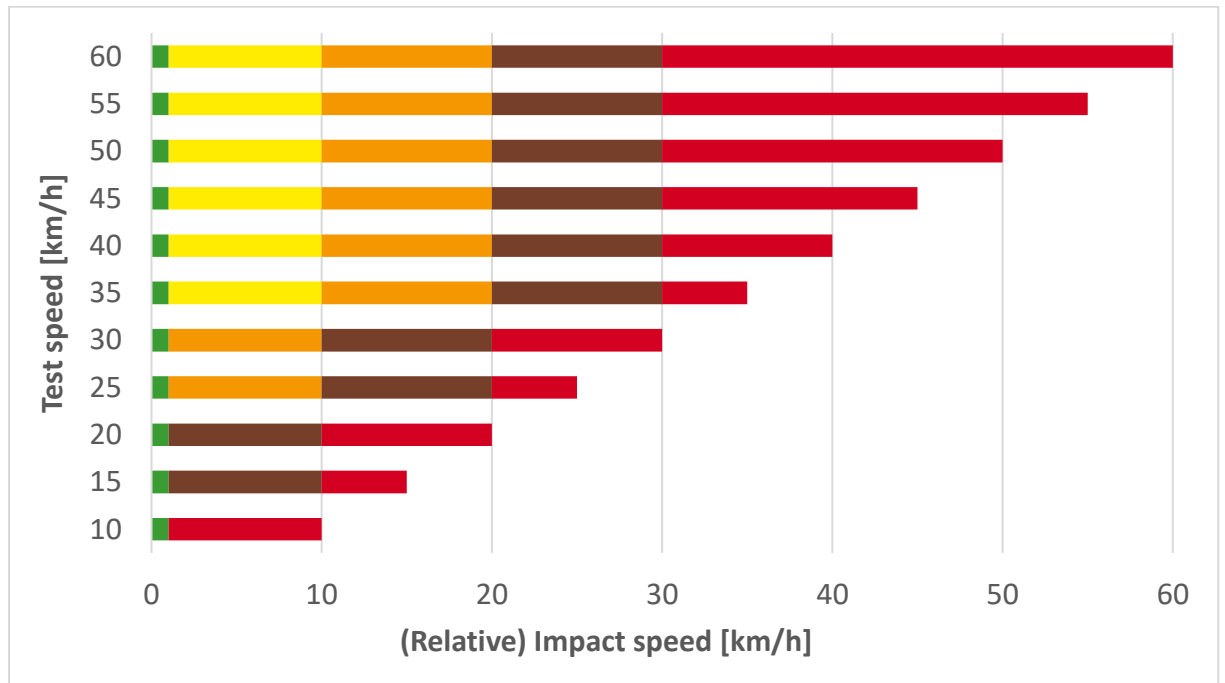

When there is an impact in any of these tests, perform a test at a test speed 5km/h less than the test speed where contact occurred. In addition perform all tests where the predicted result is Yellow, Orange or Brown. Test points that are predicted Red are excluded from testing.

In the tests above 40km/h, stop testing when the actual speed reduction measured is less than 15km/h.

For FCW systems tests, when the FCW is issued before 1.7s TTC, the subsequent test speed for the next test is incremented with 10km/h. When the FCW is issued after 1.7s TTC, first perform a test at a test speed 5km/h less than the test speed where this occurred. After this test continue to perform the remainder of the tests with speed increments of 5km/h.

Stop testing when the manufacturer predicts that the FCW is not issued before 1.5s TTC.

7.6 Test Execution

Control the VUT with driver inputs or using alternative control systems that can modulate the vehicle controls as necessary to perform the tests within the boundary conditions as specified in 7.6.1.2 for the AEB tests and XX for the LSS tests.

7.6.1 AEB tests

7.6.1.1 Accelerate the VUT and target to the respective test speeds where needed.

7.6.1.2 The test shall start at T_0 ([2s] TTC) and is valid when all boundary conditions are met between T_0 (for CPLA, CBLA-AEB & CBDA T_0-1s) and T_{AEB} and/or T_{FCW} :

	VUT	EPT	EBT	EMT
Speed	+ 0.5 km/h	± 0.2 km/h	± 0.5 km/h	± 1.0 km/h
Lateral deviation	0 ± 0.05 m	0 ± 0.05 m for crossing scenarios (incl. CPTA,CBTA & CPRA) 0 ± 0.15 m for longitudinal scenarios (incl. CBDA)		0 ± [0.15] m
Lateral velocity		0 ± 0.15 m/s	0 ± 0.15 m/s	
Relative distance				12m/40m ± 0.5m
Yaw velocity (upto T_{STEER})	0 ± 1.0 °/s			0 ± 2.0 °/s
Steering wheel velocity (upto T_{STEER})	0 ± 15.0 °/s			

7.6.1.3 The end of a test, where the AEB function is assessed, is considered when one of the following occurs:

- $V_{VUT} = 0\text{km/h}$ (crossing) or $V_{VUT} = V_{\text{target}}$ (longitudinal)
- Contact between VUT and target
- The target has left the VUT path or VUT has left the target path

For tests where the FCW function is assessed, the end of a test is considered when one of the following occurs:

- $V_{VUT} = 0\text{km/h}$ (crossing) or $V_{VUT} = V_{\text{target}}$ (longitudinal)
- $T_{\text{FCW}} < 1.5\text{s TTC}$, after which an evasive action can be started

It is at the labs discretion to select and use one of the options above to ensure a safe testing environment.

7.6.1.4 To avoid contact in the CMFtap scenario, the test laboratory may include an automated braking action by the robot in case the AEB system fails to intervene (sufficiently). This braking action is applied automatically when:

- The VUT reaches the latest position at which maximum braking applied to the vehicle will prevent the VUT entering the path of the Motorcyclist and no intervention from the AEB system is detected
- Lateral separation between the VUT and EMT reaches ≤ 0 during / after AEB intervention.

7.6.1.5 For manual or automatic accelerator control, it needs to be assured that during automatic brake the accelerator pedal does not result in an override of the system. The accelerator pedal needs to be released when the initial test speed is reduced by 5 km/h. There shall be no operation of other driving controls during the test, e.g. clutch or brake pedal. This does not apply for the CPRA tests.

7.6.1.6 The FCW system tests should be performed using a braking robot reacting to the warning with a delay time of 1.2 seconds as per C.4 to account for driver reaction time.

7.6.1.7 Braking will be applied that results in a maximum brake level of $-4 \text{ m/s}^2 - 0.50 \text{ m/s}^2$ when applied in a non-threat situation. The particular brake profile to be applied (pedal application rate applied in 200ms (max. 400mm/s) and pedal force) shall be specified by the manufacturer. When the brake profile provided by the manufacturer results in a higher brake level than allowed, the iteration steps as described in ANNEX C will be applied to scale the brake level to $-4 \text{ m/s}^2 - 0.50 \text{ m/s}^2$.

7.6.1.8 When no brake profile is provided, the default brake profile as described in ANNEX C will be applied.

7.6.2 LSS tests

7.6.2.1 The test shall start at T_0 and is valid when all boundary conditions are met between T_0 and T_{LKA}/T_{LDW} :

	VUT	EMT
(Relative) Speed	+ 0.5 km/h	± 1.0 km/h
Lateral deviation	0 ± 0.05 m	0 ± [0.15] m
Steady state lane departure lateral velocity	± 0.05m/s	
Relative distance		± 0.2m
Yaw velocity (upto T_{STEER} for VUT)	0 ± 1.0 °/s	0 ± 2.0 °/s
Steering wheel velocity (upto T_{STEER} for VUT)	0 ± 15.0 °/s	

7.6.2.2 Steer the vehicle as appropriate to achieve the lateral velocity in a smooth controlled manner and with minimal overshoot

7.6.3 The end of an CM oncoming or overtaking test is considered as when one of the following occurs:

- The system intervenes to prevent a collision between the VUT and target vehicle
- The system has failed to intervene (sufficiently) to prevent a collision between the VUT and target vehicle. This can be assumed when one of the following occurs:
 - o The lateral separation between the VUT and target vehicle equal < 0.3m in the oncoming and overtaking scenario
 - o No intervention is observed at a TTC = 0.8s or a TTC submitted by the OEM

It is at the labs discretion to select and use one of the options above to ensure a safe testing environment.

7.6.3.1 If the test ends because the vehicle has failed to intervene (sufficiently) or if the EMT has left it's designated path by more than 0.2m, it is recommended that the VUT and/or EMT are steered away from the impact, either manually or by reactivating the steering control of the driving robot/EMT.

7.6.4 The subsequent lateral velocity for the next test is incremented with 0.1m/s.

ANNEX A OBSTRUCTION DIMENSIONS

A.1 Smaller obstruction vehicle

The smaller obstruction vehicle should be of the category Small Family Car and is positioned closest to the pedestrian path. The smaller obstruction vehicle should be within the following geometrical dimensions and needs to be in a dark colour.

	Vehicle Length	Vehicle width (without mirrors)	Vehicle Height	Bonnet length (till A pillar)	BLE height
Minimum	4100 mm	1700 mm	1300 mm	1100 mm	650 mm
Maximum	4400 mm	1900 mm	1500 mm	1500 mm	800 mm

A.2 Larger obstruction vehicle

The larger obstruction vehicle should be of the category Small Off-road 4x4 and is positioned behind the smaller obstruction vehicle. The larger obstruction vehicle should be within the following geometrical dimensions and needs to be in a dark colour.

	Vehicle Length	Vehicle width (without mirrors)	Vehicle Height
Minimum	4300 mm	1750 mm	1500 mm
Maximum	4700 mm	1900 mm	1800 mm

ANNEX B TESTING AT LOW AMBIENT LIGHTING CONDITIONS

B.1 Illumination Situation

Based on a GIDAS hotspot analysis, this appendix will describe a test condition for a night test scenario in urban situations.

B.2 Reference EN 13201

This European Standard defines performance requirements, which are specified as lighting classes for road lighting aiming at the visual needs of road users, and it considers environmental aspects of road lighting.

EN 13201, Road lighting is a series of documents that consists of the following parts:

- Part 1: Guidelines on selection of lighting classes [Technical Report];
- Part 2: Performance requirements [present document];
- Part 3: Calculation of performance;
- Part 4: Methods of measuring lighting performance;
- Part 5: Energy performance indicators.

B.3 Terms and definitions

E - horizontal illuminance over a road area measured in lux (lx)

$\overline{E_{min}}$ - horizontal illuminance averaged over a road area measured in lux (lx).

E_{min} - lowest illuminance on a road area measured in lux (lx).

$\overline{E_{max}}$ - horizontal illuminance averaged over a road area measured in lux (lx).

Reference point R - The reference point of the lamp shall be the geometric centre of the light field

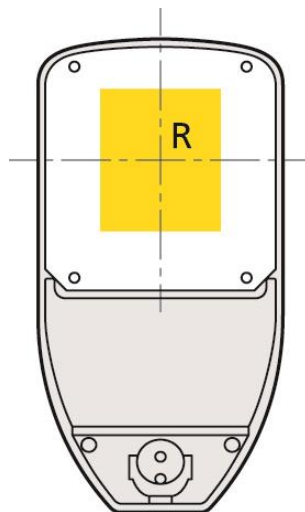

B.3.1

Derivation of parameter

The test condition in this appendix is based on accident analysis. The illumination values refer to DIN EN 13201.

The main illumination situations are main roads in urban situations with velocity 30...60 km/h, where main users are motorized vehicles and where bicycles and pedestrians are permitted.

The illuminance is based on class ME3. For ME3 comparative classes are available: C3 und S1. For Illuminance class S1 following values are defined in EN 13201:

Values for Class S1:

$$\overline{E_{min}} > 15lx \text{ AND } E_{min} > 5lx$$

$$\overline{E_{max}} < 1,5 * \overline{E_{min}} \text{ AND } \overline{E_{max}} < 22,5lx$$

$\overline{E_{ref}}$ - In order to reach a stable measurement setup, a reference value is defined as:

$$\overline{E_{ref}} = \frac{\overline{E_{min}} + \overline{E_{max}}}{2} = \frac{15lx + 22,5lx}{2} = 18,75lx$$

B.4

Light condition

There is a wide range of illuminance values in different situations. (see figure below).

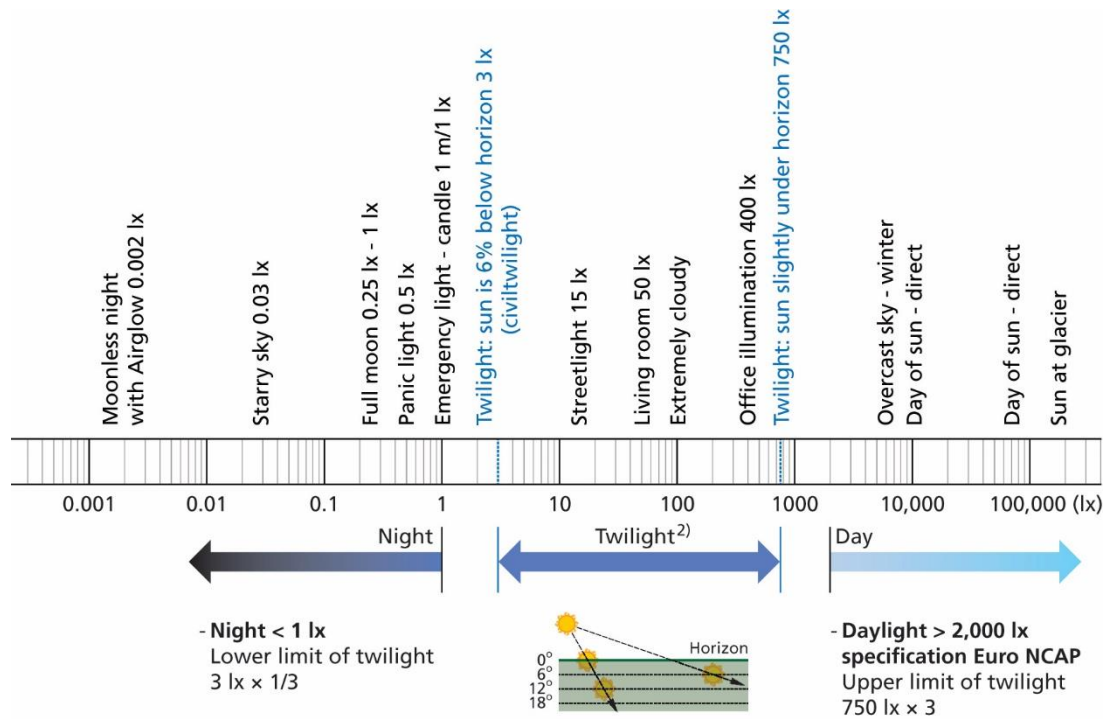

B.4.1 Background illuminance

The background illumination is an additive value to the streetlight illumination.

The position of the measurement of the background illumination shall be measured at the collision point. During measurement of background illumination all lamps and vehicle light shall be switched off.

Maximum of the background illumination on a test area during night shall be less than:

$$I_{EB} < 1lx$$

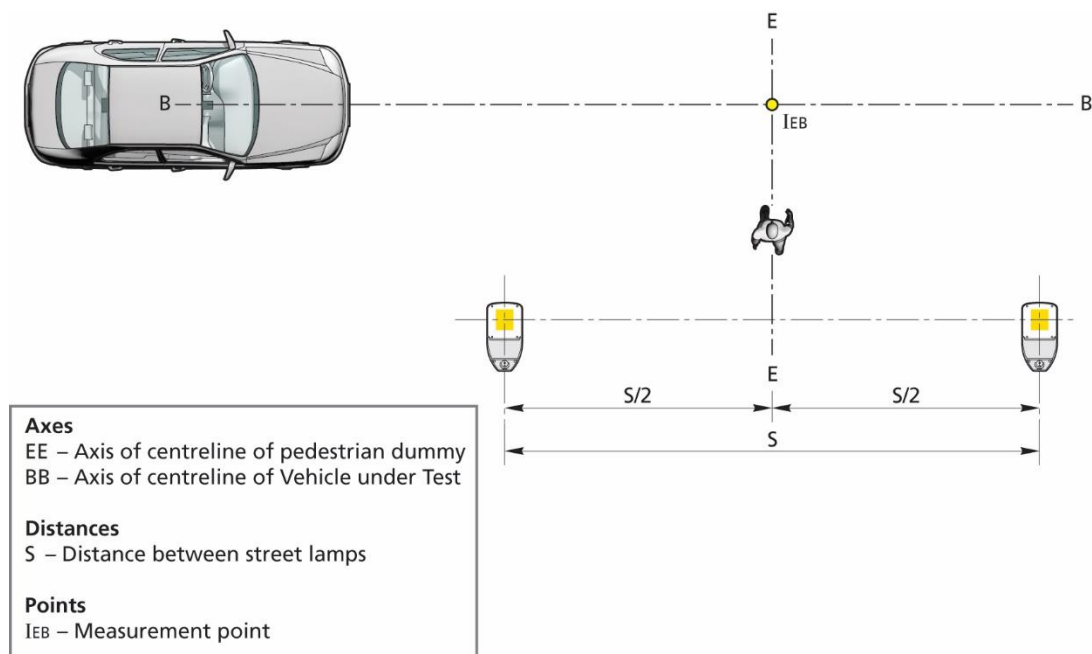

B.4.2 Illuminance at VUT path

The illuminance of VUT path (\overline{IVUT}) is defined as an average of illuminance measurement points along the VUT path, trajectory BB. The average illuminance shall be in a range of:

$$\overline{IVUT} = \overline{E_{ref}} \pm Tolerance = 19lx \pm 3lx$$

$$\overline{IVUT} = \frac{1}{11} \sum_{i=1}^{11} IVUT_i; \quad 16lx < \overline{IVUT} < 22lx$$

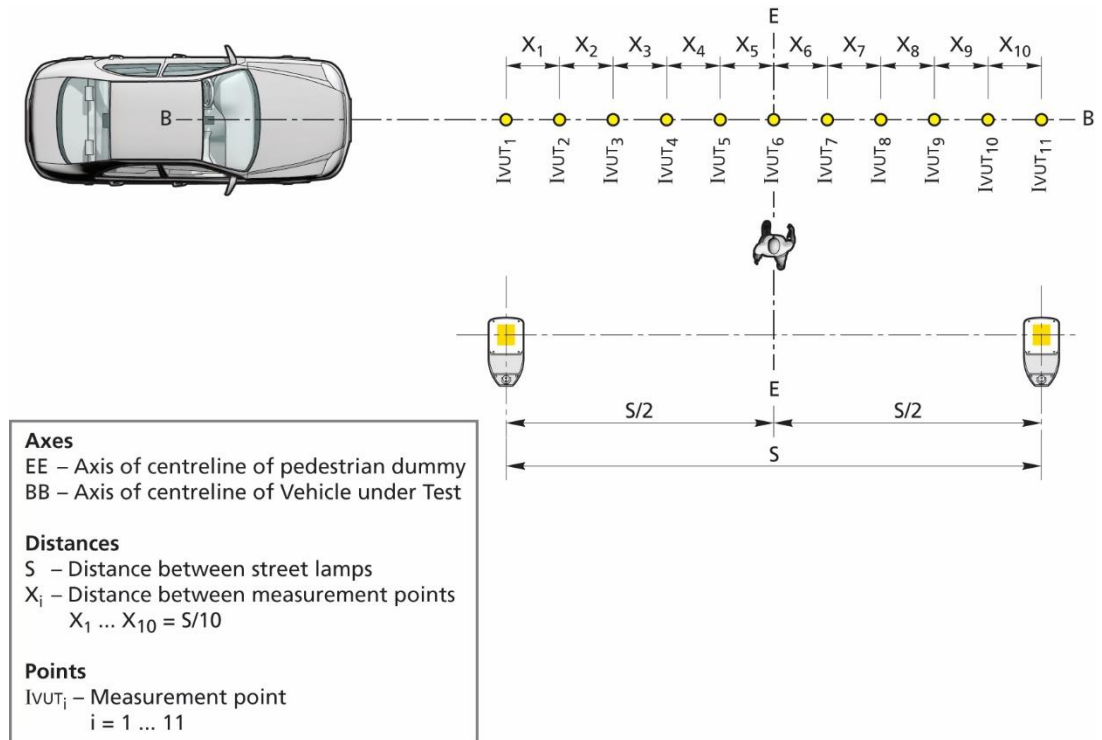

B.4.3

Illuminance at EPT path

The illuminance along the EPT path, trajectory EE shall be at least $I_{EPT_i} > E_{min}$

$$I_{EPT_i} > 5lx$$

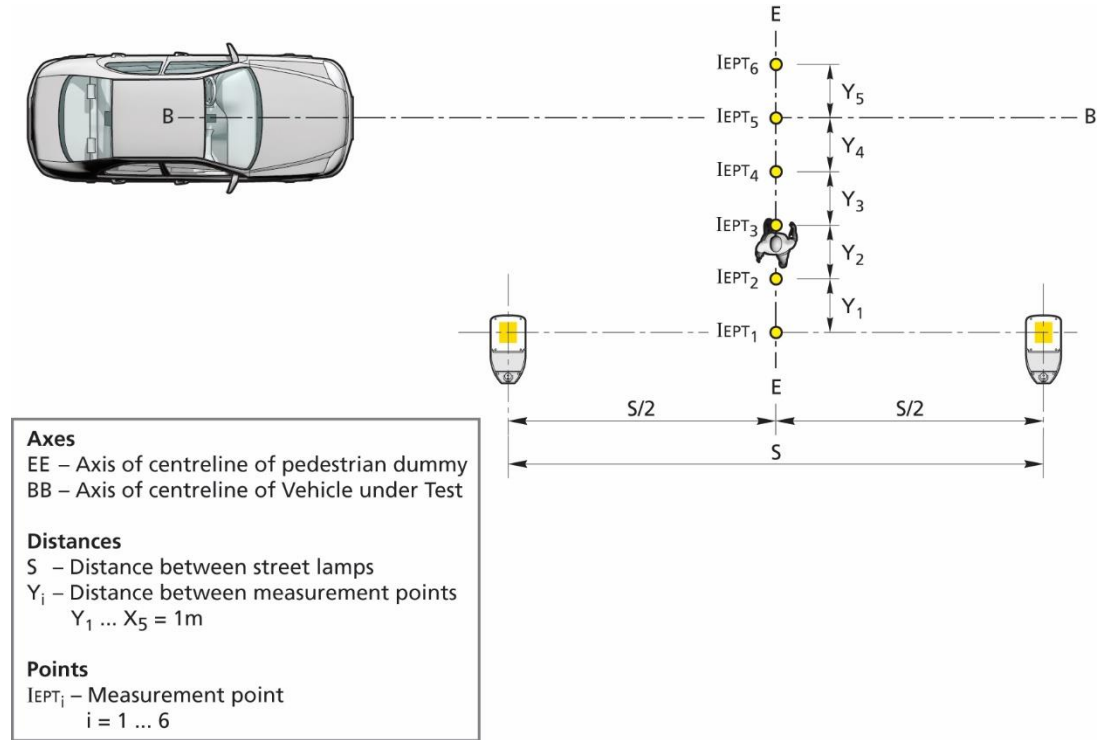

B.4.4

Measurement tolerances

All measurement tolerances shall be

$$E : \pm 1lx$$

B.5 Test Equipment

B.5.1 General requirement

The chosen lamp setup must reflect real world conditions. It is not allowed to install separate lamps to reach the required conditions. For the night test, a LED lamp shall be used due to its overall advantages like homogeneous illumination, long-term stability, power consumption etc.

B.5.2 Glaring

The lamps shall not be tilted towards the SV path to avoid any glaring which could affect the sensor performance. Glaring of the sensor system shall not occur everywhere on the test area and especially not along the section of the vehicle path.

B.5.3 Constant illumination function

To reach constant test conditions during test and lifetime, the lamp shall have a constant illumination function.

B.5.4 Colour temperature

The colour temperature of the lamps shall be between $4500 \pm 1000\text{K}$.

B.5.5 Mounting device

The lamps can be either installed stationary on a fixed pole, or on a mobile tripod. The mounting device must be designed to withstand wind speeds up to 20m/s.

B.5.6 Free Space (F)

In the passenger side of the VUT test path it is not allowed to install any mounting device from the lamp.

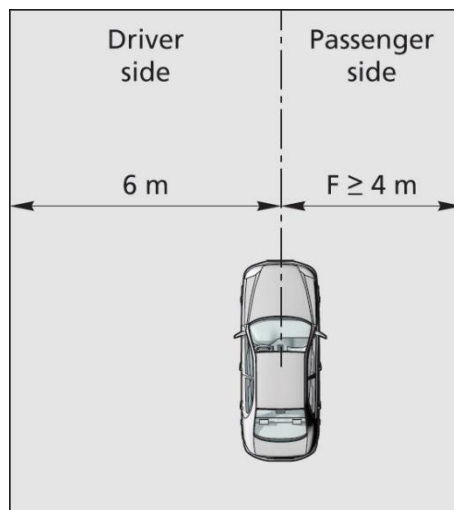

The free space F between the VUT path and the mounting facility shall be **$F \geq 4\text{m}$** .

B.5.7 Test setup

Three lamps in front of the pedestrian path and two lamps behind the pedestrian path are recommended (see figure below). That lamp configuration provides a homogeneous illumination of the test scenario according to real world situations. The position of the EPT is between lamp 3 and 4.

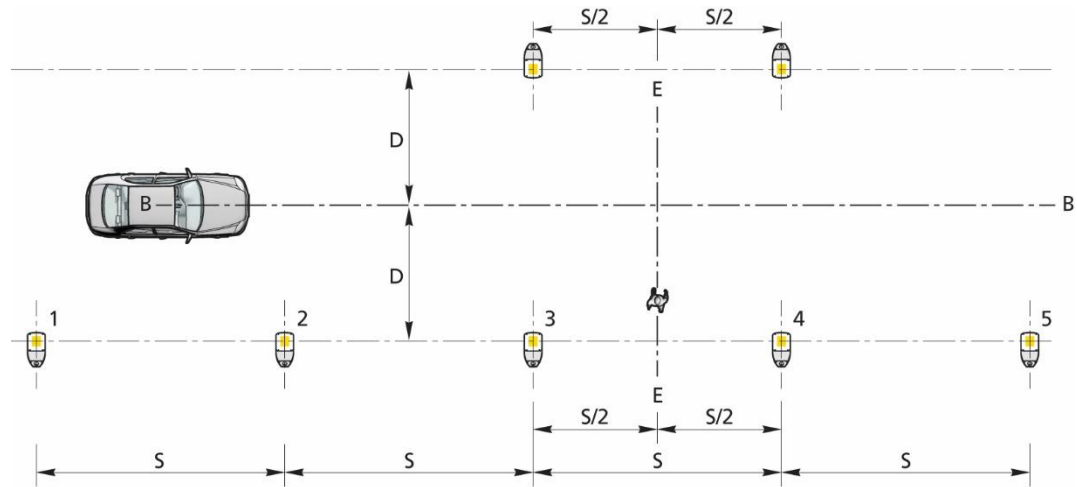

Axes

EE – Axis of centreline of pedestrian dummy

BB – Axis of centreline of Vehicle under Test

Distances

D – Lateral distance between the centre of the light field and the Vehicle under Test path

S – Distance between street lamps

B.5.8

EPT position

The EPT track EE shall be positioned between the street lamp 3 and 4 and passes the centreline of the EPT. Reference point for test setup is trajectory AA, which passes the pedestrian dummy H-point.

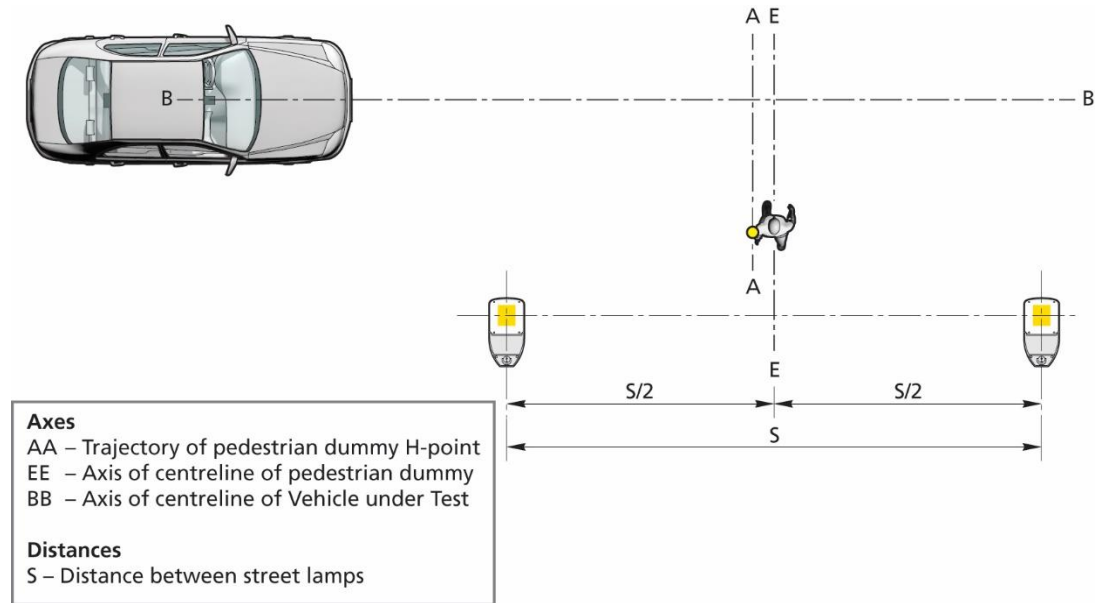

B.6 Example Test Equipment

As a reference and to demonstrate feasibility, the following sections provides example test equipment, test set-up and reference measurements that can be taken to ensure that the set-up will meet the requirements of this ANNEX.

Lamp type

Schuch, 48_LED (48 2403 ABX CL)

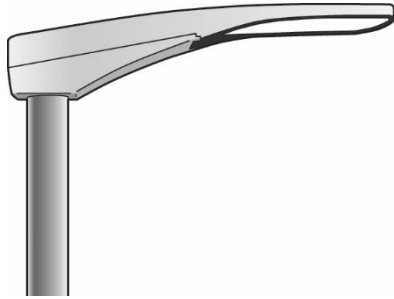

B.6.1 Requirement test setup adjustment

To be sure to reach requirement B4.2 and B4.3 the following parameters are allowed to be adjusted.

The distance of the lamp should be adjustable in order to reach the requested illumination values.

S: 25m ± 0,5m

The lateral distance between the centre of the LED-area and the vehicle path is adjustable in a range of

D: 4,0m ± 0,1m

The height of the lamp should be adjustable in order to reach the requested illumination values.

H: 5m ± 0,1m

Angle against ground and pole.

a : 90° ± 0,5°

The tilt of the lamp is adjustable in three different positions. (0° standard, 5°, 10°)

T: 0° standard position

The inclination of road and test site surfaces is typically ~2.5%

c: < 1,5°

To ensure that the centre lines L of the lamps are oriented at right angles to the street even under the above conditions the length of the control line C shall be verified.
Approval for the two lamps adjacent to the pedestrian path is sufficient.

$$C = \sqrt{D^2 + H^2} = \sqrt{4m^2 + 5m^2}$$

C: 6,4m ± 0,1m

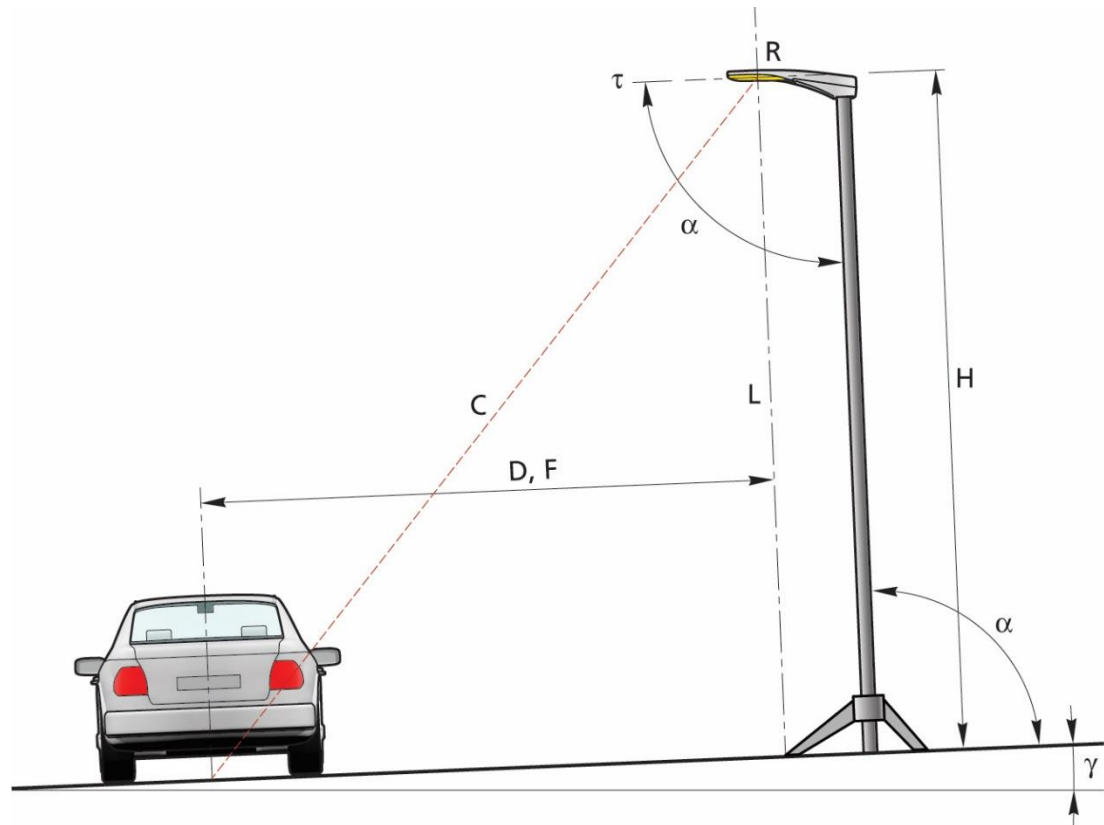

- R – Reference point geometric centre of the light field
- L – Centre line of the lamp (parallel to the pole)
- D – Lateral distance between the centre of the light field and the VUT path
- F – Free space between driving path of VUT and equipment
- H – Height of lamp
- C – Control line
- τ – Tilt of lamp
- α – Angle against ground and pole
- γ – Cross slope

B.6.2

Longitudinal inclination of lamp

In order to get well balanced light distribution, it is necessary that the inclination of the lamp is in a range of:

$\beta_{1,2}: 90^\circ \pm 0.5^\circ$

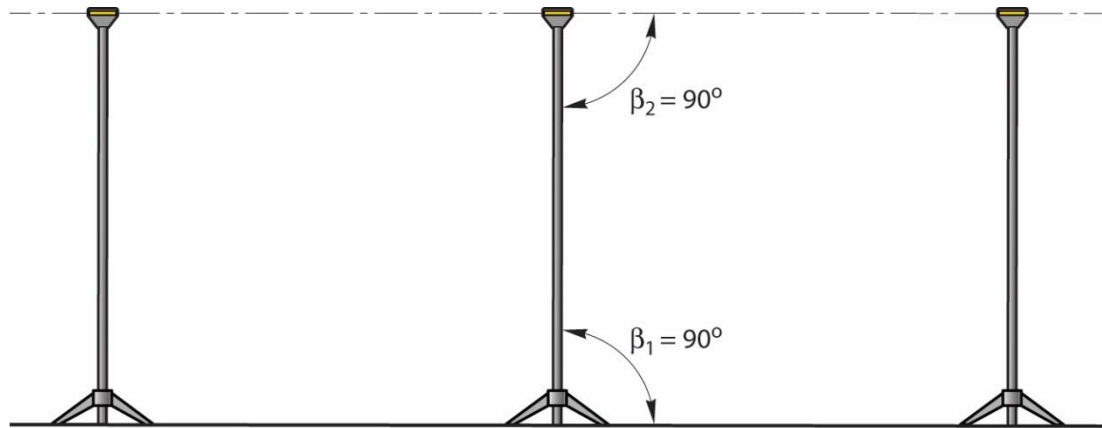

β_1 – Inclination of lamp to ground
 β_2 – Inclination of lamp to pole

B.6.3

Orientation of lamp

In order to get well balanced light distribution, it is necessary that the rotation of the lamp in a range of:

$$\rho: 90^\circ \pm 0,1^\circ$$

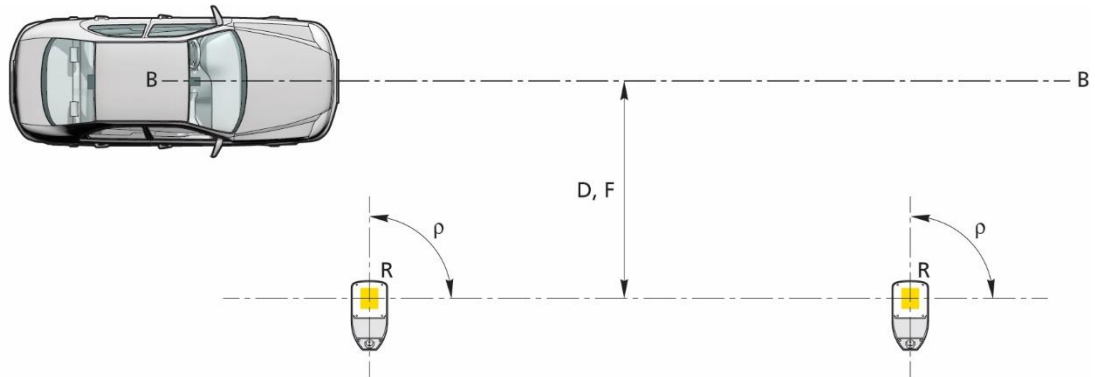

Axes BB – Axis of centreline of Vehicle under Test
Angles ρ – rotation of lamp
Distances F – Free space between driving path of VUT and equipment D – Lateral distance between the centre of the light field and the VUT path
Points R – Reference point geometric centre of the light field

B.6.4

Example solutions

It is not allowed to install any mounting device within the free space. Different solutions are possible to reach the requirement as defined in B5.6.

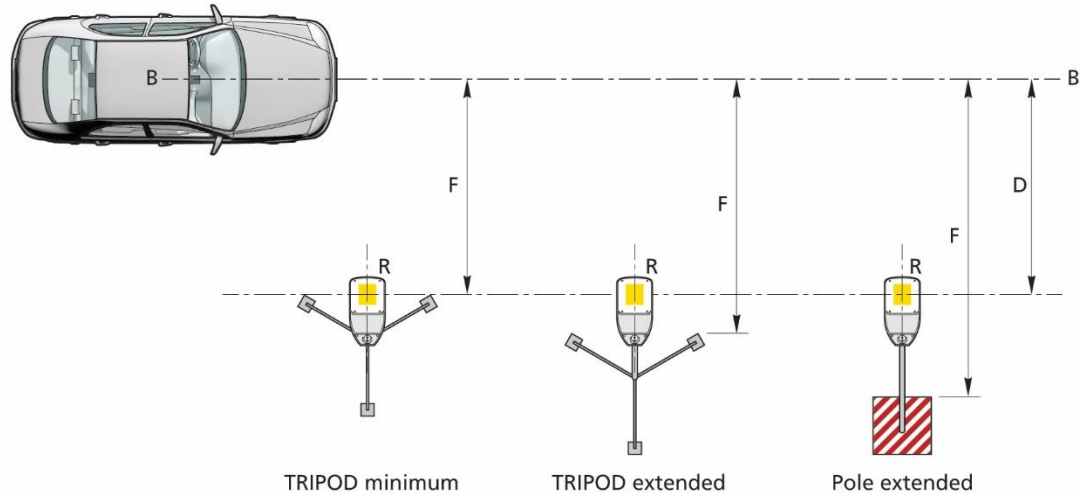
**Axes**

BB – Axis of centreline of Vehicle under Test

Distances

F – Free space between driving path of VUT and equipment

D – Lateral distance between the centre of the light field and the VUT path

Points

R – Reference point geometric centre of the light field

B.6.5

Example mounting devices

It is not allowed to install any mounting device within the free space. Different solutions are possible to reach the requirement as defined in B5.6.

Towerlight TF5.5

<http://www.towerlight.de/produkt/tf-5-5-7m/>

(Date 2017-05-15)



configuration tripod



configuration cement pole

B.7 Measurement

To ensure, that the parameter defined in B4.1, B4.2 and B4.3 are in line with test setup, the parameter must be verified and documented.

B.7.1 Measurement setting

To measure the illumination, a calibrated luxmeter must be set on ground in a right angle to the street.

P: < 0,2m

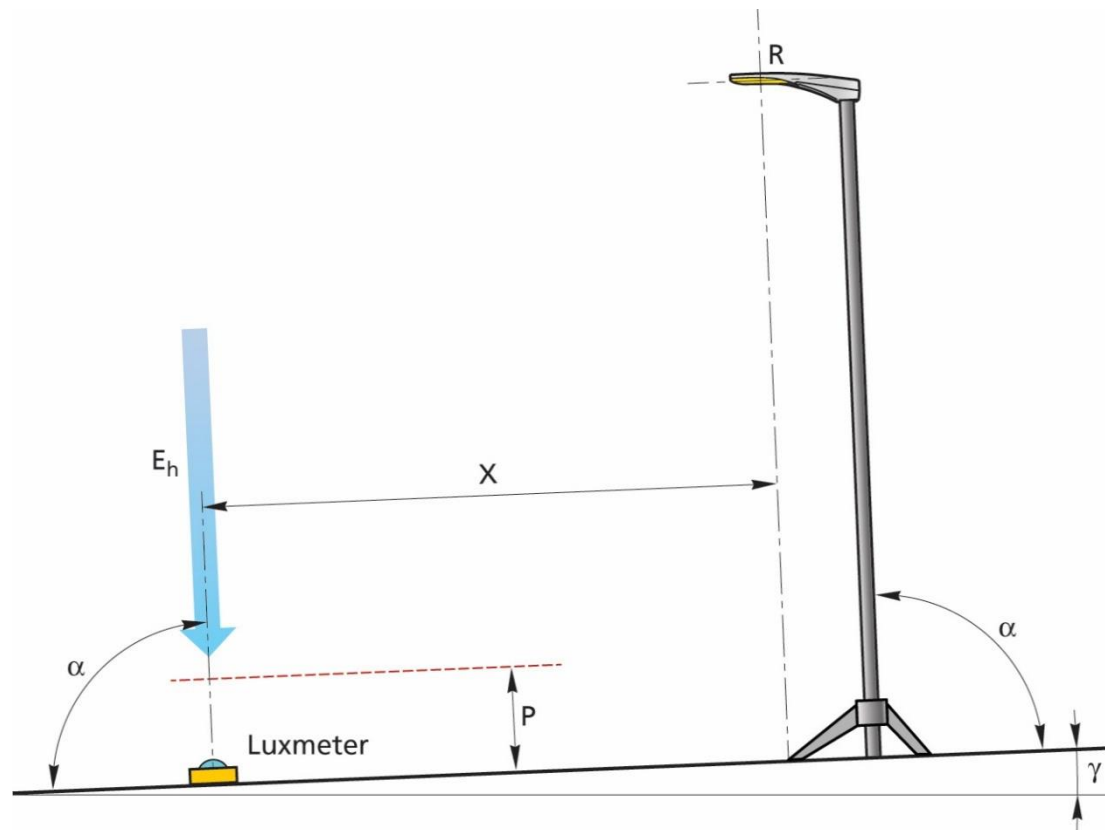

<p>E_h – Horizontal illumination R – Reference point geometric centre of light field P – Maximal height over ground X – Position X α – Angle against ground γ – Cross slope</p>
--

B.7.2 Example measurement grid

To ensure, that the parameter defined in B4.1, B4.2 and B4.3 are in line with test setup, the parameter must be verified and documented.

For I EPT5, I VUT6, I EB the position for measurement is:

X=12,5m, Y=4,0m.

The other values see figure below.

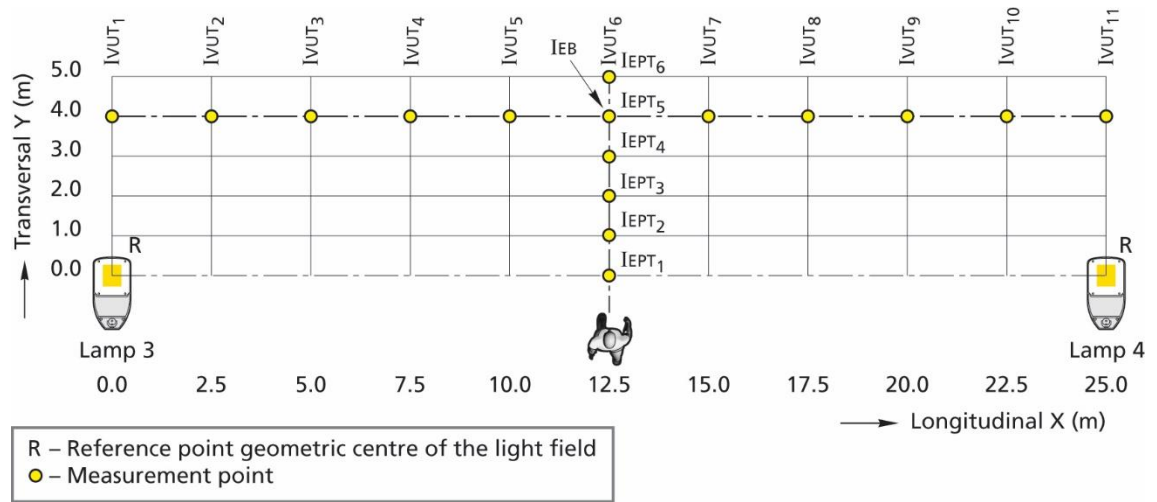

B.7.3

Example measurement tools

To measure the illuminance values, a calibrated luxmeter shall be used. The tolerance shall be:

Maximal error tolerance < 5%.

Luxmeter LMT B 360

<http://www.lmt-berlin.de/de/b360.html>

(Date 2017-05-15)



Luxmeter LMT B 360

Luxmeter Konika T-10A

<https://www.konicaminolta.eu/de/messgeraete/produkte/licht-messtechnik/luxmeter/t-10a/einfuehrung.html>

(Date 2017-05-15)



figure: Luxmeter Konika T-10A

B.7.4 Measurement documentation

The following values shall be measured and documented before and after a complete test series.

- **Background illuminance I_{EB} (B.4.1)**
With all lamps and vehicle lights switched OFF, measure and record I_{EB} before and after a full test series.
- **Illuminance at VUT, EPT path (B.4.2 & B.4.3)**
With all lamps ON and vehicle lights OFF, measure and record the illuminance at VUT and EPT path.

ANNEX C BRAKE APPLICATION PROCEDURE

The braking input characterisation test determines the brake pedal displacement and force necessary to achieve a vehicle deceleration typical of that produced by a typical real-world driver in emergency situations.

C.1 Definitions

T_{BRAKE} - The point in time where the brake pedal displacement exceeds 5mm.

T_{-6m/s²} - The point in time is defined as the first data point where filtered, zeroed and corrected longitudinal acceleration data is less than -6m/s^2 .

T_{-2m/s²}, **T_{-4m/s²}** - similar to **T_{-6m/s²}**.

C.2 Measurements

Measurements and filters to be applied as described in Chapter 4 of this protocol.

C.3 Brake Characterization Procedure

First perform the brake and tyre conditioning tests as described in 8.1.2 and 8.1.3. The brake input characterisation tests shall be undertaken within 10 minutes after conditioning the brakes and tyres.

C.3.1 Brake Displacement Characterisation Tests

- Push the brake pedal through the full extent of travel and release.
- Accelerate the VUT to a speed in excess of 85km/h. Vehicles with an automatic transmission will be driven in D. For vehicles with a manual transmission select the highest gear where the RPM will be at least 1500 at the 85km/h.
- Release the accelerator and allow the vehicle to coast. At a speed of $80 \pm 1.0\text{km/h}$ initiate a ramp braking input with a pedal application rate of $20 \pm 5\text{mm/s}$ and apply the brake until a longitudinal acceleration of -7m/s^2 is achieved. For manual transmission vehicles, press the clutch as soon as the RPM drops below 1500. The test ends when a longitudinal acceleration of -7m/s^2 is achieved.
- Measure the pedal displacement and applied force normal to the direction of travel of the initial stroke of the brake pedal, or as close as possible to normal as can be repeatedly achieved.

C.3.1.1 Perform three consecutive test runs. A minimum time of 90 seconds and a maximum time of 10 minutes shall be allowed between consecutive tests. If the maximum time of 10 minutes is exceeded, perform three brake stops from 72 km/h at approximately 0.3g.

- Using second order curve fit and the least squares method between **T_{-2m/s²}**, **T_{-6m/s²}**,

calculate the pedal travel value corresponding to a longitudinal acceleration of -4 m/s^2 ($=D4$, unit is m). Use data of at least three valid test runs for the curve fitting.

- This brake pedal displacement is referred to as $D4$ in the next chapters.
- Using second order curve fit and the least squares method between $T-2\text{m/s}^2$, $T-6\text{m/s}^2$, calculate the pedal force value corresponding to a longitudinal acceleration of -4 m/s^2 ($=F4$, unit is N). Use data of at least three valid test runs for the curve fitting.
- This brake pedal force is referred to as $F4$ in the next chapters.

C.3.2 Brake Force Confirmation and Iteration Procedure

- Accelerate the VUT to a speed of $80+1\text{km/h}$. Vehicles with an automatic transmission will be driven in D. For vehicles with a manual transmission select the highest gear where the RPM will be at least 1500 at the 80km/h .
- Apply the brake force profile as specified in B.4, triggering the input manually rather than in response to the FCW. Determine the mean acceleration achieved during the window from $T_{\text{BRAKE}} + 1\text{s}$ $T_{\text{BRAKE}} + 3\text{s}$. If a mean acceleration outside the range of $-4-0.5\text{m/s}^2$ results, apply the following method to ratio the pedal force applied.
 $F4_{\text{new}} = F4_{\text{original}} * (-4/\text{mean acceleration})$, i.e. if $F4_{\text{original}}$ results in a mean acceleration of -5m/s^2 , $F4_{\text{new}} = F4_{\text{original}} * -4 / -5$
- Repeat the brake force profile with this newly calculated $F4$, determine the mean acceleration achieved and repeat the method as necessary until a mean acceleration within the range of $-4-0.5\text{m/s}^2$ is achieved.

C.3.2.1 Three valid pedal force characteristic tests (with the acceleration level being in the range as specified) are required. A minimum time of 90 seconds and a maximum time of 10 minutes shall be allowed between consecutive tests. If the maximum time of 10 minutes is exceeded, perform three brake stops from 72 km/h at approximately $0.3g$.

- before restarting the brake pedal force characterisation tests. This brake pedal force is referred as $F4$ in the next chapters.

C.4 Brake Application Profile

- Detect T_{FCW} during the experiment in real-time.
- Release the accelerator at $T_{\text{FCW}} + 1 \text{ s}$.
- Perform displacement control for the brake pedal, starting at $T_{\text{FCW}} + 1.2 \text{ s}$ with a gradient of the lesser of $5 \times D4$ or 400mm/s (meaning the gradient to reach pedal position $D4$ within 200ms , but capped to a maximum application rate of 400mm/s).
- Monitor brake force during displacement control and use second-order filtering with a cut-off frequency between 20 and 100 Hz (online) as appropriate.
- Switch to force control, maintaining the force level, with a desired value of $F4$ when

- i. the value $D4$ as defined in B.3 is exceeded for the first time,
 - ii. the force $F4$ as defined in B.3 is exceeded for the first time, whichever is reached first.
- The point in time where position control is switched to force control is noted as T_{switch} .
 - Maintain the force within boundaries of $F4 \pm 25\% F4$. A stable force level should be achieved within a period of 200ms maximum after the start of force control. Additional disturbances of the force over $\pm 25\% F4$ due to further AEB interventions are allowed, as long as they have a duration of less than 200ms.
 - The average value of the force between $T_{\text{FCW}} + 1.4\text{s}$ and the end of the test should be in the range of $F4 \pm 10\text{ N}$.